

Definition of Modbus RTU on the RS485-bus

Version 1.04



Contents

1	INTRODUCTION	4
1.1	MOTIVATION	4
1.2	SCOPE OF THE DOCUMENT.....	4
1.3	VALUES	4
2	ARCHITECTURAL OVERVIEW	5
2.1	BUS TOPOLOGY	5
2.2	DATA FLOW.....	5
3	HARDWARE REQUIREMENTS	6
3.1.1	<i>RS485 Logical Signal Levels</i>	6
3.2	SUPPORTED WILO DEVICES	6
4	PROTOCOL	7
4.1	BYTE ORDERING AND FORMAT	7
4.1.1	<i>Supported Baud rates</i>	7
4.2	PACKET FIELDS	7
4.2.1	<i>Address field</i>	7
4.2.2	<i>Function field</i>	8
4.2.3	<i>Data field</i>	8
4.2.4	<i>Checksum field</i>	8
4.3	PACKETS.....	8
4.3.1	<i>Function 03 – Read Holding register</i>	9
4.3.2	<i>Function 04 – Read Input register</i>	9
4.3.3	<i>Function 06 – Preset single register</i>	10
4.3.4	<i>Function 08 – Return Query Data</i>	10
4.4	PROTOCOL TIMING	11
4.4.1	<i>Byte Level</i>	11
4.4.2	<i>Packet Level</i>	11
4.5	PROTOCOL ERROR HANDLING	12
4.5.1	<i>Error 1 – Illegal function</i>	12
4.5.2	<i>Error 2 – Illegal data address</i>	13
4.5.3	<i>Error 3 – Illegal data value</i>	13
4.5.4	<i>Error 11 – Gateway target device failed to respond</i>	13
4.5.5	<i>Gateway Communication Timeout</i>	13
5	DEVICE PARAMETERS.....	14
5.1	WRITE-POINT PARAMETERS	14
5.1.1	<i>Set value</i>	14
5.1.2	<i>Pump Command</i>	15
5.1.3	<i>Operation Mode</i>	15
5.1.4	<i>T_{min} for Δp-T</i>	15
5.1.5	<i>T_{max} for Δp-T</i>	16
5.1.6	<i>p_{min} for Δp-T</i>	16
5.1.7	<i>p_{max} for Δp-T</i>	16
5.2	READ-POINT PARAMETERS (SINGLE PUMP).....	17
5.2.1	<i>Actual Differential Pressure</i>	17
5.2.2	<i>Flow Rate</i>	18
5.2.3	<i>Power Consumption</i>	18
5.2.4	<i>Power Rating</i>	18
5.2.5	<i>Operation Hours</i>	18
5.2.6	<i>Mains Current</i>	18
5.2.7	<i>Speed</i>	18
5.2.8	<i>Medium Temperature</i>	18
5.2.9	<i>Current Operation Mode</i>	19
5.2.10	<i>Pump Module</i>	19
5.2.11	<i>Pump Type</i>	19
5.2.12	<i>Max Speed</i>	21

5.2.13	<i>Min Speed</i>	21
5.2.14	<i>Max Pressure $\Delta p-c$</i>	21
5.2.15	<i>Min Pressure $\Delta p-c$</i>	21
5.2.16	<i>Max Pressure $\Delta p-v$</i>	21
5.2.17	<i>Min Pressure $\Delta p-v$</i>	21
5.2.18	<i>Max Flow Rate</i>	22
5.2.19	<i>Min Flow Rate</i>	22
5.2.20	<i>Supported Errors</i>	22
5.2.21	<i>Supported Service Messages</i>	22
5.2.22	<i>Max Power Rating</i>	23
5.2.23	<i>Service Message</i>	23
5.2.24	<i>Error Type</i>	23
5.2.25	<i>Error Message</i>	23
5.2.26	<i>Pump Status</i>	24
5.2.27	<i>State Diagnostics</i>	25
5.3	READ-POINT PARAMETERS (SPECIAL FOR A DOUBLE PUMP)	25
5.3.1	<i>Operating Hours DP</i>	26
5.3.2	<i>Actual Differential Pressure (Slave)</i>	26
5.3.3	<i>Flow Rate (Slave)</i>	26
5.3.4	<i>Power Consumption (Slave)</i>	26
5.3.5	<i>Power Rating (Slave)</i>	26
5.3.6	<i>Operating Hours (Slave)</i>	26
5.3.7	<i>Mains Current (Slave)</i>	27
5.3.8	<i>Speed (Slave)</i>	27
5.3.9	<i>Pump Module (Slave)</i>	27
5.3.10	<i>Pump Type (Slave)</i>	27
5.3.11	<i>Error Type (Slave)</i>	27
5.3.12	<i>Pump Status (Slave)</i>	27
6	PUMP SUPPORT	28
6.1	WRITE-POINT PARAMETERS	28
6.1.1	<i>Pump Command</i>	28
6.1.2	<i>Operation Mode</i>	28
6.2	READ-POINT PARAMETERS (SINGLE PUMP)	29
6.2.1	<i>Pump Module</i>	30
6.2.2	<i>Service Message</i>	30
6.2.3	<i>Error Type</i>	30
6.2.4	<i>Error Message</i>	31
6.2.5	<i>Pump Status</i>	31
6.2.6	<i>State Diagnostics</i>	32
6.3	READ-POINT PARAMETERS (SPECIAL FOR A DOUBLE PUMP)	32
7	TRANSACTION EXAMPLES	33
7.1	SINGLE PUMP	33
7.1.1	<i>Example 1: Simple Write</i>	33
7.1.2	<i>Example 2: Simple Read</i>	33
7.1.3	<i>A Write example with an error response</i>	33
7.2	DOUBLE PUMP	33
7.2.1	<i>Example 4: Simple Read</i>	34
8	VERSION HISTORY	35

1 Introduction

1.1 Motivation

In order to make configuration and operation easier, many building components support some way of remote controlling. This remote controlling does not only make it possible for the janitor to monitor devices and open gates or doors, letting the roller blinds down etc. But it also makes automatic changes, as turning down the temperature at 6 p.m. or perhaps even when the last person has left.

In short: The communication between devices are becoming more and more common, and more and more different devices are connected to the main computer in order to allow what could be seen as an intelligent building.

This document describes the protocol that will enable a remote control of pumps and thus make it possible to incorporate them in the main building management system.

1.2 Scope of the Document

This document describes the protocol and is targeted to developers that need to communicate with Wilo pumps.

In the second chapter, a brief device setup is shown and some fundamental knowledge is described.

In the third chapter the hardware requirements are briefly explained. This chapter is only included as assistance and is not to be thought of as a complete hardware specification.

The fourth chapter describes the protocol, how a packet is built, what order the bytes have, the meaning of the packets and the timing of packets and signals. It also explains the error handling in the protocol.

The fifth chapter describes all read and write parameters and their function.

The sixth chapter contains detailed communication examples to a pump.

1.3 Values

All values in this document are decimal unless prefixed with "0x" for a hexadecimal value.

2 Architectural Overview

2.1 Bus Topology

The main computer or BMS is called master since it effectively request information from the pumps. All Gateways (or in extension, the pumps) are slaves and they only passively responds to the requests from the master.

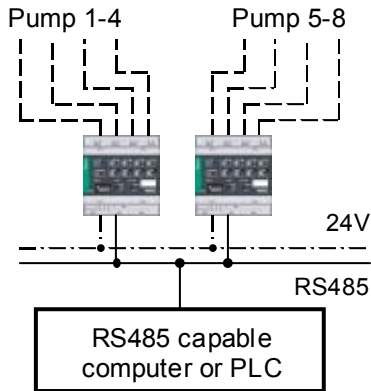

Figure 2.1, Example of a simple configuration

2.2 Data Flow

The DigiCon (the gateway to the pumps) continually reads data from all its pumps and acts as a provider of this data on the RS485-bus. Similarly it collects the data from all writes and gives it to the corresponding connected Pump.

The communication on the RS485-bus is always master initiated. After a request an answer or timeout must take place, it is not allowed to send another request without waiting for an answer or timeout. Timing is described at the end of chapter 4.

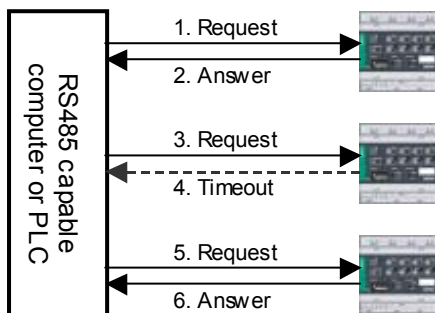

Figure 2.2, Example of the data flow

The data is requested and sent by the master. It is then received and responded to by a slave. A slave cannot by itself initiate a transfer.

3 Hardware Requirements

The protocol described in this document is using the industry standard RS485 (for a specification see TIA/EIA-485). It is a two-wire bus protocol describing the physical and electrical levels of the wires. RS485 supports up to 32 connected transceivers (units) including the master, and allow a cable length up to 1000 meters.

Note: Make sure that the ends of the RS485 bus are correctly terminated by a 120 Ohm resistor (See DigiCon Manual for further information).

3.1.1 RS485 Logical Signal Levels

When no unit is transmitting, A is negative and B is positive with respect to ground. In RS485 this level is specified as a logical '1'. Before any RS485 device sends its data on the bus, all units must know what format the data has, how many data bits, eventual a parity bit and how many stop bits. When data is to be sent it is always preceded by one start bit (a logical '0'). The data is transmitted with the LSB (bit 0) first and the data is followed by the eventual parity bit and then the stop bit (a logical '1').

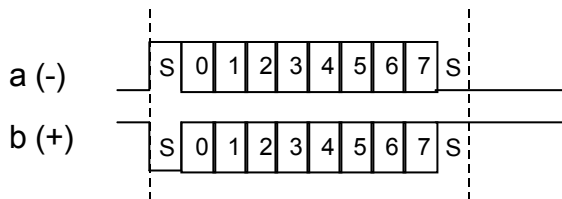

Figure 3.1, RS485 logical signal levels

3.2 Supported Wilo devices

This specification applies to the following products.

Art.-No.	Description	Manufacturer
2061843	DigiCon - Modbus	Wilo

Table 3.1, Products, compliant to Modbus RTU over RS485.

4 Protocol

Only Modbus RTU (over RS485) is supported. ASCII and other Ethernet variants of the Modbus protocol are not supported.

4.1 Byte Ordering and format

In Modbus, one byte can be transmitted in different byte formats. It is important to verify that the correct byte format is used. All supported byte formats are shown in the Table below.

DigiCon – Modbus DIP Switch ¹	Data Bits	Stop Bits	Parity
xx11xx	8	2	None
xx01xx	8	1	None
xx00xx	8	1	Even
xx10xx	8	1	Odd

¹⁾ The two DIP Switches in the middle of the six, placed under the casing of the DigiCon – Modbus (from left to right, a “1” means on, “0” means off and a “x” is a don’t care).

Table 4.1, Supported byte formats

All data bits are sent LSB First and the bits are also numbered in this order, LSB = bit 0.

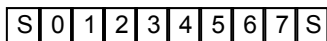

Figure 4.1, one byte with a start bit, no parity and one stop bit

No handshake protocol is implemented and a whole packet can be sent without a pause. Usually there are no gaps within a packet. Byte ordering is High byte before Low byte. For example: The value 3000 (0x0BB8) is sent as 0x0B, 0xB8.

Note: The CRC-Checksum is sent with a different byte ordering as the other bytes, Low byte first.

4.1.1 Supported Baud rates

The DigiCon - Modbus supports the following baud rates: 2400, 9600, 19200 and 115200.

4.2 Packet Fields

The packets consist of several different fields, and each field is defined as described below.

4.2.1 Address field

The address field is always one byte and can contain the values 0 to 255. It contains the address of the slave that is addressed or the slave answering a request. The master always uses this field to direct the message to a specific slave. The slave always writes its own address in this field in order to tell the master from whom the answer came.

No device can have the address “0”, because it is the broadcast address. Commands sent on this address will be seen by all devices on the bus and none is allowed to answer.

Note: the addresses 248 to 255 are reserved and cannot be used. See Modbus RTU Specification for more information.

4.2.2 Function field

Every packet has a function field and it describes the structure of the packet. The function field has the size of one byte. It can have the values described in Table 4.2 and furthermore it can contain error information. If the MSB (bit 7) is high it means that an error has occurred and that the following packet data contains the error code.

Only the slave is allowed to send the highest bit of the function field as a “1”. If any Function is used, other than those presented here, the device will answer with this high bit and an error code. See Chapter 4.5 for more information about error codes.

4.2.3 Data field

The data in the Data field is depending on what function is sent. Each request and response packet for a function has different data in the Data field. See each function for a closer description what the packet must contain.

4.2.4 Checksum field

The checksum has the size of exactly two bytes, and it is the CRC16 sum of all bytes before the checksum. The exact algorithm is described in the “Modbus over Serial Line” Specification. In short, the start value is 0xFFFF and the 16 bit polynomial is $x^{15}+x^{13}+1$.

Examples of correct calculated CRC-Sums can be found in chapter 6.

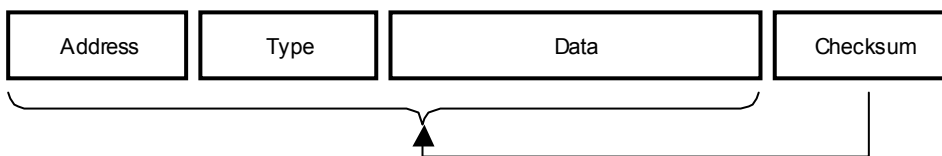

Figure 4.2, Checksum

If a request contained an error and resulted in a checksum error, there will be no answer to the request. If the answer contained an error, the master would most likely send a similar request again.

4.3 Packets

Four different functions are supported. Each function has a request and a response packet. A slave can, instead of answering with a response packet, answer with an error, more about errors in Chapter 4.5.

Function field	Request description
03	Read holding registers (Write-Points)
04	Read input registers (Read-Points)
06	Preset single register (Write-Point)
08	Return query data

Table 4.2, Supported Functions

Each packet consists of four blocks, Device address, Function code, Data and CRC. All fields have defined sizes except for the Data field. The size of the data field can range from 0 to 252 bytes. A packet can be up to 256 bytes long.

1 byte	1 byte	N bytes	2 bytes
Device address	Function code	Data	CRC

Figure 4.3, The packet structure.**4.3.1 Function 03 – Read Holding register**

This function is used to read one or more Holding registers (Write-Points). The master always initiates the request and the slave always answers.

The first byte of the request is the device address and the second is the number 3 for read holding registers function. After these two bytes comes the start address, describing the Holding register address that is going to be read. Followed by the number of addresses that are to be read from this point on. At the end of the packet the checksum is sent. It is the checksum for all bytes in the packet not including the checksum itself.

Request Packet Field	Size	Value
Device Address	1 byte	Address
Function Code	1 byte	0x03
Starting Address	2 bytes	0x0000 to 0xFFFF
Quantity of Registers	2 bytes	1 to 125 (0x7D)
CRC	2 bytes	CRC

Table 4.3, Function 3, Request packet

The slave must answer with a Response or an error if the CRC-Sum was correctly calculated.

The first byte of the response is the device address and the second is the number 3 for read holding registers function. After these two bytes comes the number of bytes returned. This number (divided by two) is the number of returned data points following the "Byte count" byte. At the end of the packet the checksum is sent. It is the checksum for all bytes in the packet not including the checksum itself.

Response Packet Field	Size	Value
Device Address	1 byte	Address
Function Code	1 byte	0x03
Byte Count	1 byte	2 x N*
Register Values	N* x 2 bytes	Register Contents
CRC	2 bytes	CRC
<i>N* = Quantity of Registers</i>		

Table 4.4, Function 3, Response Packet**4.3.2 Function 04 – Read Input register**

This function is used to read one or more Input registers (Read-Points). The master always initiate the request and the slave always answers. The packets are the same as for the function 3, with the only difference that they have the function code 4 instead of 3.

Request Packet Field	Size	Value
Device Address	1 byte	Address
Function Code	1 byte	0x04
Starting Address	2 bytes	0x0000 to 0xFFFF
Quantity of Registers	2 bytes	1 to 125 (0x7D)
CRC	2 bytes	CRC

Table 4.5, Function 4, Request Packet

The response packets are also the same as for the function 3.

Response Packet Field	Size	Value
Device Address	1 byte	Address
Function Code	1 byte	0x04
Byte Count	1 byte	2 x N*
Register Values	N* x 2 bytes	Register Contents
CRC	2 bytes	CRC
<i>N* = Quantity of Registers</i>		

Table 4.6, Function 4, Response Packet

4.3.3 Function 06 – Preset single register

This function is used to write a single holding register (Write-Point). The master always requests and the slave always answers.

The first byte of the request is the device address and the second is the number 6 for preset single register function. After these two bytes comes the start address, describing the Holding register address that is going to be written. Followed by the actual value that is to be written. At the end of the packet the checksum is sent. It is the checksum for all bytes in the packet not including the checksum itself.

Request Packet Field	Size	Value
Device Address	1 byte	Address
Function Code	1 byte	0x06
Register Address	2 bytes	0x0000 to 0xFFFF
Register Value	2 bytes	0x0000 to 0xFFFF
CRC	2 bytes	CRC

Table 4.7, Function 6, Request Packet

The slave must answer with a Response or an error if the CRC-Sum was correctly calculated. The response packet is formatted exactly as the request packet. When it is transmitted it is the definitive response that the value has been properly written to the slave's memory.

Note: In the case where the slave is a gateway it can take additional time before the value reaches the pump. In the case of DigiCon – Modbus this can be up to a few seconds.

Response Packet Field	Size	Value
Device Address	1 byte	Address
Function Code	1 byte	0x06
Register Address	2 bytes	0x0000 to 0xFFFF
Register Value	2 bytes	0x0000 to 0xFFFF
CRC	2 bytes	CRC

Table 4.8, Function 6, Response Packet

4.3.4 Function 08 – Return Query Data

This function is used to check the quality of the bus wiring and connections. The slave mirrors the packet to the last bit and sends it unchanged back to the master. The sub-function "00" is the only sub-function that is supported.

The first byte of the request is the device address and the second is the number 8 for Return query data function. The next byte must be 0x0000 because it is the only supported sub-function. After these four bytes comes the data, it can be as long as wanted (the packet size is limited to 256 bytes) and the last two bytes are the checksum.

Request Packet Field	Size	Value
Device Address	1 byte	Address
Function Code	1 byte	0x06
Sub-Function	2 bytes	
Data	N x 2 bytes	0x0000 to 0xFFFF
CRC	2 bytes	CRC

Table 4.9, Function 8, Request and Response packet

4.4 Protocol Timing

In order to allow for a stable communication, the Modbus RTU protocol has several specified timing constraints.

4.4.1 Byte Level

A bit time is derived from the baud rate. The byte size in Modbus can vary between 10 and 11 bits. For all calculations using a byte (character) time, the size 11 is used. This means that even though the bit length of a transmitted byte is 10, the value 11 is used for timing calculations.

Usually there are no delays in a transmitted packet. In a Packet the Between Byte time can be as small as 0 ms and is not allowed to exceed 1.5 Character times.

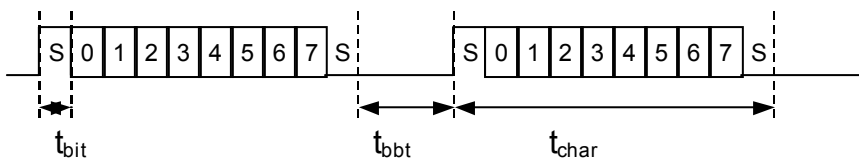

Figure 4.4, Byte level timing

Name	Description	Specified Time
t_{bit}	Bit time	1 / Baud rate (s)
t_{char}	Character time	11 / Baud rate (s)
t_{bbt}	Between byte time	0 to $(1.5 \times t_{char}) \text{ ms}^{1,2}$

¹⁾ Packets with a between byte time larger than specified value will be discarded by the slave.
²⁾ If this time is smaller than 1 ms. The time 1 ms is used.

Table 4.10, Byte level timing

4.4.2 Packet Level

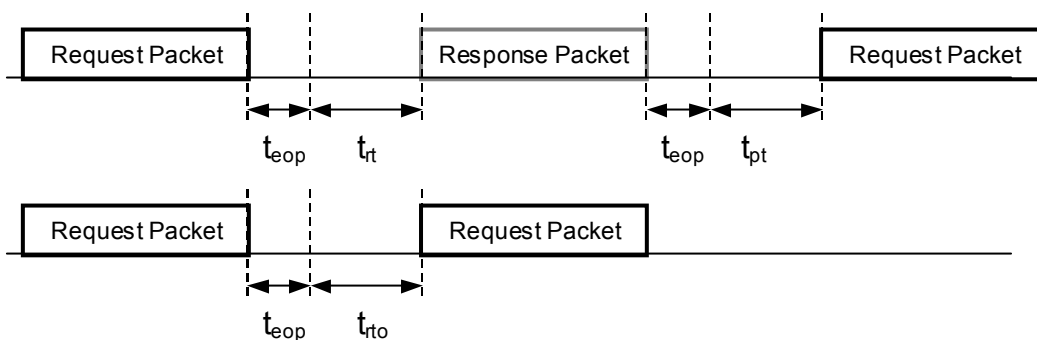

Figure 4.5, Packet level timing

Name	Description	Specified Time
t_{eop}	End of packet time	Max $(3.5 \times t_{char})$ ms ¹
t_{rt}	Response time	Max 30 ms
t_{rto}	Response time out	30 ms
t_{pt}	Processing time	Max 30 ms

¹⁾ Packets with a between byte time larger than specified value will be discarded by the slave.

²⁾ If this time is smaller than 2 ms. The time 2 ms is used.

Table 4.11, Packet level timing

This means that the slave can discard the packet if a between byte time of more then 1,5 character times is found, and similarly it must detect that it is a new frame if this pause is more than 3,5 character times.

The resulting waiting time that the master must wait for an answer (turn around time), would then be following:

Baud	Character Time (t_{char})	Turn around time ($t_{eop}+t_{rt}$)
2400	4,58 ms	46,0 ms
9600	1,15 ms	34,0 ms
19200	0,573 ms	32,0 ms
115200	0,0955 ms	32,0 ms ¹

¹⁾ t_{eop} is lower than 2 ms and thus increased to 2 ms.

Table 4.12, Turn around time values for specific baud rates

Note: The Modbus RTU protocol is not intended for remote regulation. It can come to a delay up to a few seconds before the pump accepts the new value.

4.5 Protocol Error Handling

If a function or a feature is wanted that the slave does not support, the slave sends an error packet. This packet can be identified from the highest bit of the “function code” byte. If this high bit is “1” then the packet is an error packet and does not follow the format of a normal response packet. The Error packet is defined as follows.

Request Packet Field	Size	Value
Device Address	1 byte	Address
Function Code	1 byte	Bit 7 = 1, plus Function code
Exception Code	1 byte	See Table 4.14
CRC	2 bytes	CRC

Table 4.13, Error packet

The new field, “exception code”, is defined as follows:

Exception Code (Decimal)	Description
01	Illegal function
02	Illegal data address
03	Illegal data value
11	Gateway target device failed to respond

Table 4.14, Exception codes

4.5.1 Error 1 – Illegal function

If a function is requested that is not supported by the slave, this error is sent as a response.

4.5.2 Error 2 – Illegal data address

If the master tries to read or write a Write- or Read-Point that is not supported. This error will be returned. If a range of Write- or Read-Points are requested and one of them is not supported, this error will be returned.

Note: All pumps do not support all Write- and Read-Points. The master software must be able to handle the situation when the pump does not support a Write- or Read-Point. The Points that are supported can be found in Chapter 6, Pump Support.

4.5.3 Error 3 – Illegal data value

If a value is written to a Write-Point that is out of range of the specified min and max values the slave can send this error back. This Error is optional and must not be implemented.

4.5.4 Error 11 – Gateway target device failed to respond

The DigiCon buffers the last value from the pump up to a minute after it has stopped transmitting. After this minute the Error 11 is returned on every request. In order to assure that an accidental reset of the DigiCon or the pump, does not trigger the communication timeout to this pump in the Building management system, it is suggested to wait one minute after receiving the first Error 11. If still no data is returned within this minute the master should issue a pump communication timeout for that specified pump.

4.5.5 Gateway Communication Timeout

If the Gateway is powered off it does not answer any requests for all its connected pumps, even if the pumps are still running. This must be detected by the master and the master should issue a Gateway communication timeout if no requests has been answered within a minute after the first unanswered request.

5 Device Parameters

The Device Parameter space is split in two parts, the Write-Point parameters and the Read-Point parameters.

Note: The Write-Point parameter with address 1 is thus not the same as the Read-Point parameter with address 1. They even have different Units.

5.1 Write-Point Parameters

Write-Point address	Description	Data Type	Unit
1	Set Value	32	0.5%
40	Pump Command	1	See Table 5.2
42	Operation Mode	1	See Table 5.3
44	Tmin for Δp -T	32	0.1 K
45	Tmax for Δp -T	32	0.1 K
46	pmin for Δp -T	32	0.1 m WS ¹
47	pmax for Δp -T	32	0.1 m WS ¹

¹⁾ 1 m WS \approx 9.8 kPa = 0.098 bar

Table 5.1, Write-Point addresses

5.1.1 Set value

Write-Point address: 1
Type: 32
Value range: 0 to 200
Unit: 0.5 %

The set value sets the wanted Speed or Pressure (depending on Operation mode, see section 5.1.3) in percent. Everything below the minimum value (speed or pressure, X_{min}) of the pump is ignored, and the pump runs at minimum value (see Figure 5.1). It is not possible to turn the pump off with this parameter.

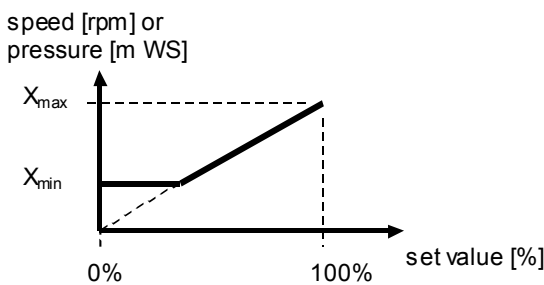

Figure 5.1, Set value curve

Note: The Set Value should be sent as the last Write-Point in a packet.

5.1.2 Pump Command

Write-Point address: 40
Type: 1
Value range: 0 to 0xFF
Unit: see Table 5.2

This Write-Point controls the on, off, max speed and min speed modes of the pump.

Note: "max speed" has priority over "min speed" and "on/off", and "min speed" has priority over "on/off".

Bit number	Bit = 1	Bit = 0	Note
0	Pump on	Pump off	Bit number 1 and 2 has priority
1	Min Speed ¹	Normal operation	Bit number 2 has priority
2	Max Speed	Normal operation	
3	Reserved	Not allowed	Must always be '1'

All other bits must be set to '0'

¹⁾ *The actual speed in the Min Speed mode can differ slightly from the "min speed" Read-Point, it depends on what pump is connected and if it has a special value specified.*

Table 5.2, Pump Command bit set

5.1.3 Operation Mode

Write-Point address: 42
Type: 1
Value range: 0-6
Unit: see Table 5.3

This Write-Point controls the operation mode of the pump. If a specified pump does not support the current selected mode it goes in mode 3 (Δp -c). The current operation mode can be read back by the Read-Point 11 (see section 5.2.9).

Value	Operation mode
0	Unknown
1	Fixed speed
2	Reserved
3	Δp -c regulation
4	Δp -v regulation
5	Reserved
6	Δp -T regulation

All other values are reserved and should not be used

Table 5.3, Operation Mode value

5.1.4 T_{\min} for Δp -T

Write-Point address: 44
Type: 32
Value range: 0 to (T_{\max})
Unit: 0.1 K

This Write-Point sets a parameter for the temperature regulation. See Figure 5.2. This value must be lower than the value for T_{\max} .

5.1.5 T_{max} for Δp -T

Write-Point address: 45
Type: 32
Value range: (T_{min}) to 65534
Unit: 0.1 K

This Write-Point sets a parameter for the temperature regulation. See Figure 5.2. This value must be higher than the value for T_{min} .

5.1.6 p_{min} for Δp -T

Write-Point address: 46
Type: 32
Value range: 0 to 65534
Unit: 0.1 m WS (≈ 0.98 kPa = 0.0098 bar)

This Write-Point sets a parameter for the temperature regulation. See Figure 5.2. This value can be lower or higher than the value for p_{max} .

5.1.7 p_{max} for Δp -T

Write-Point address: 47
Type: 32
Value range: 0 to 65534
Unit: 0.1 m WS (≈ 0.98 kPa = 0.0098 bar)

This Write-Point sets a parameter for the temperature regulation. See Figure 5.2. This value can be lower or higher than the value for p_{min} .

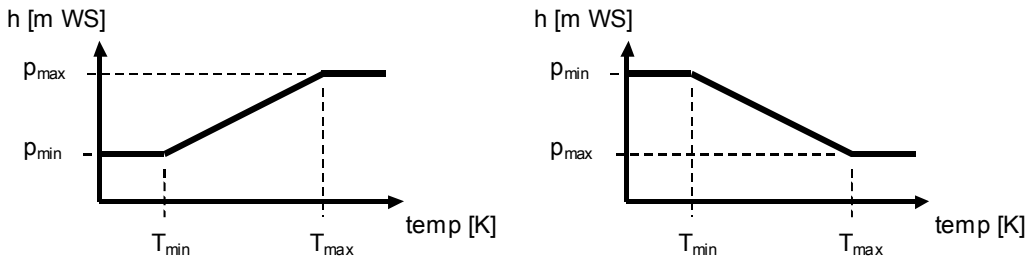

Figure 5.2, Δp -T regulation with a high or low slope

5.2 Read-Point Parameters (Single Pump)

Some pumps do not support some parameters. This means that some parameters can be left unanswered. Also some parameters give a special value when this parameter is not supported.

Note: When a pump not supports a specific Read-Point parameter and leaves this parameter out of the response packet, the main control must be able to handle this and must not go into an unspecified state or crash.

Read-Point address	Description	Data Type	Unit
1	Actual Differential Pressure	32	0.1 m WS ¹
2	Flow Rate	32	0.1 m ³ /h
3	Power Consumption	3	1 kWh
4	Power Rating	3	1 W
5	Operation Hours	33	10 h
6	Mains Current	32	0.1 A
7	Speed	3	1 rpm
8	Medium Temperature	32	0.1 K
10	Current Operation Mode	1	See Table 5.3.
16	Pump Module	1	See Table 5.5.
17	Pump Type	1	See Table 5.6.
18	Max Speed	3	1 rpm
19	Min Speed	3	1 rpm
20	Max Pressure Δp -c	32	0.1 m WS ¹
21	Min Pressure Δp -c	32	0.1 m WS ¹
22	Max Pressure Δp -v	32	0.1 m WS ¹
23	Min Pressure Δp -v	32	0.1 m WS ¹
24	Max Flow Rate	32	0.1 m ³ /h
25	Min Flow Rate	32	0.1 m ³ /h
26	Supported Errors	3	See Table 5.9.
27	Supported Service Messages	3	See Table 5.7.
28	Max Power Rating	3	1 W
35	Service Message	3	See Table 5.7.
36	Error Type	3	See Table 5.8.
37	Error Message	3	See Table 5.9.
38	Pump Status	3	See Table 5.10.
39	State Diagnostics	3	See Table 5.11.

¹⁾ 1 m WS \approx 9.8 kPa = 0.098 bar

Table 5.4, Read-Point addresses

5.2.1 Actual Differential Pressure

Read-Point address: 1
Type: 32
Value range: 0 to 65535
Unit: 0.1 m WS (\approx 0.98 kPa = 0.0098 bar)

This Read-Point returns the actual differential pressure.

5.2.2 Flow Rate

Read-Point address: 2
Type: 32
Value range: 0 to 65535
Unit: 0.1 m³/h

This Read-Point returns the current flow rate.

Note: A pump that does not support this Read-Point sets the value to 9999 (decimal).

5.2.3 Power Consumption

Read-Point address: 3
Type: 3
Value range: 0 to 65535
Unit: 1 kWh

This Read-Point returns the total power consumption in kWh.

5.2.4 Power Rating

Read-Point address: 4
Type: 3
Value range: 0 to 65535
Unit: 1 W

This Read-Point returns the current power rating in Watts.

5.2.5 Operation Hours

Read-Point address: 5
Type: 33
Value range: 0 to 65535
Unit: 10 h

This Read-Point returns the operation hours in steps of 10 hours.

5.2.6 Mains Current

Read-Point address: 6
Type: 32
Value range: 0 to 65535
Unit: 0.1 A

This Read-Point returns the mains current in steps of 0.1 Amperes

5.2.7 Speed

Read-Point address: 7
Type: 3
Value range: 0 to 65534
Unit: 1 rpm

This Read-Point returns the current speed in rpm.

5.2.8 Medium Temperature

Read-Point address: 8
Type: 32
Value range: 0 to 65535
Unit: 0.1 K

This Read-Point returns the Temperature. This value is only supported if the pump has a temperature sensor (TOP-E and STRATOS).

Note: When this value is not supported, the pump does usually not respond to this Read-Point.

5.2.9 Current Operation Mode

Read-Point address: 10
Type: 1
Value range: 0 to 8
Unit: See Table 5.3.

This Read-Point returns the current operation mode.

5.2.10 Pump Module

Read-Point address: 16
Type: 1
Value range: 0 to 255
Unit: see Table 5.5.

This Read-Point returns if the pump module is frequency converter regulated or not.

Bit number	Bit = 1	Bit = 0	Note
0	Pump is regulated with a frequency-converter	Pump is not regulated	

All other bits are unspecified and can be either '0' or '1'.

Table 5.5, Pump Module Info

5.2.11 Pump Type

Read-Point address: 17
Type: 1
Value range: 0 to 255
Unit: see Table 5.6.

This Read-Point returns the pump type (see Table 5.6).



Value	Pump Type	Value	Pump Type
1	TOP-E 40 / 1 – 10 EP/DP	51	STRATOS 25/1-6 EP
2	TOP-E 50 / 1 – 7 EP/DP	52	STRATOS 30/1-6 EP
3	TOP-E 50 / 1 – 10 EP/DP	53	STRATOS 40/1-4 EP
4	TOP-E 65 / 1 – 10 EP/DP	54	STRATOS 25/1-8 EP
5	TOP-E 80 / 1 – 10 EP/DP	55	STRATOS 30/1-8 EP/DP
6	TOP-E 80 / 1 – 10n EP/DP	56	STRATOS 25/1-12 EP
7	TOP-E 25 / 1 – 7 EP		
8	TOP-E 30 / 1 – 10 EP	60	MHIE 205
9	TOP-E 40 / 1 – 4 EP	61	MHIE 403
10	TOP-E 50 / 1 – 6 EP/DP	62	MVIE 205
11	TOP-E 30 / 1 – 7 EP/DP	63	MVIE 403
12	TOP-E 40 / 1 – 10 IR EP/DP	64	MHIE 405
13	TOP-E 50 / 1 – 7 IR EP/DP	65	MHIE 803
14	TOP-E 50 / 1 – 10 IR EP/DP	66	MHIE 1602
15	TOP-E 65 / 1 – 10 IR EP/DP	67	MVIE 208
16	TOP-E 80 / 1 – 10 IR EP/DP	68	MVIE 406
17	TOP-E 40 / 1 – 7 IR EP/DP	69	MVIE 803
18	TOP-E 100 / 1 – 10 IR EP/DP	70	MVIE 1602
		71	MHIE 806
20	IP-E 32 / 5 – 28 EP/DP	72	MHIE 1603
21	IP-E 40 / 2 – 12 EP/DP	73	MVIE 214
23	IP-E 40 / 5 – 28 EP/DP	74	MVIE 410
24	IP-E 50 / 2 – 12 EP/DP	75	MVIE 806
26	IP-E 50 / 5 – 28 EP/DP	76	MVIE 1603
27	IP-E 65 / 2 – 15 EP/DP	77	MVISE 206
29	IP-E 65 / 4 – 20 EP/DP	78	MVISE 404
30	IP-E 80 / 2 – 15 EP/DP	79	MVISE 406
31	IP-E 80 / 4 – 20 EP/DP	80	MVISE 803
		81	MVISE 210
32	IL-E 50/10-36 EP(IL)/DP(DL)	82	MVISE 410
33	IL-E 65/6-24 EP(IL)/DP(DL)	83	MVISE 806
34	IL-E 80/5-22 EP(IL)/DP(DL)	84	SHCE20
35	IL-E 40/9-39 EP(IL)/DP(DL)		
36	IP-E 50/140-3/2 EP/DP	90	MVIE 414
37	IP-E 80/130-3/2 EP/DP	91	MVIE 808
38	IP-E 40/160-4/2 EP/DP	92	MVIE 1605
39	IP-E 65/140-4/2 EP/DP	93	MVIE 3202
		94	MVIE 811
40	STRATOS 30/1-12 EP	95	MVIE 1607
41	STRATOS 40/1-8 EP/DP	96	MVIE 3203
42	STRATOS 50/1-8 EP/DP	97	MVIE 5202
43	STRATOS 32/1-12 EP/DP		
44	STRATOS 40/1-12 EP/DP	101	IP-E 32/100-0.55/2
45	STRATOS 50/1-12 EP/DP	102	IP-E 32/110-0.75/2
46	STRATOS 50/1-9 EP/DP	103	IP-E 40/120-1.5/2
47	STRATOS 65/1-9 EP	104	IP-E 40/130-2.2/2
48	STRATOS 65/1-12 EP/DP	105	IP-E 50/130-2.2/2
49	STRATOS 80/1-12 EP/DP		
50	STRATOS 100/1-12 EP/DP		

Table 5.6, Pump Types

5.2.12 Max Speed

Read-Point address:	18
Type:	3
Value range:	0 to 65535
Unit:	1 rpm

This Read-Point returns the max possible speed of the pump. It is the speed that is set when operation mode is set to “fixed speed” and the set value is set to 100%.

5.2.13 Min Speed

Read-Point address:	19
Type:	3
Value range:	0 to 65535
Unit:	1 rpm

This Read-Point returns the min possible speed. It is the speed that is set when the operation mode is set to “fixed speed” and the set value is below the corresponding percentage for min speed.

5.2.14 Max Pressure Δp -c

Read-Point address:	20
Type:	32
Value range:	0 to 65535
Unit:	0.1 m WS (≈ 0.98 kPa = 0.0098 bar)

This Read-Point returns the max possible pressure. It is the pressure that is set when operation mode is set to “ Δp -c regulation” and the set value is set to 100%.

5.2.15 Min Pressure Δp -c

Read-Point address:	21
Type:	32
Value range:	0 to 65535
Unit:	0.1 m WS (≈ 0.98 kPa = 0.0098 bar)

This Read-Point returns the min possible pressure. It is the pressure that is set when the operation mode is set to “ Δp -c regulation” and the set value is below the corresponding percentage for min pressure.

5.2.16 Max Pressure Δp -v

Read-Point address:	22
Type:	32
Value range:	0 to 65535
Unit:	0.1 m WS (≈ 0.98 kPa = 0.0098 bar)

This Read-Point returns the max possible pressure. It is the pressure that is set when operation mode is set to “ Δp -v regulation” and the set value is set to 100%.

Note: pumps that does not support “ Δp -v regulation” either sets the values to the same as the Δp -c max value or does not respond with data on this Read-Point. This Read-Point should not be used to see if the pump supports Δp -v regulation.

5.2.17 Min Pressure Δp -v

Read-Point address:	23
Type:	32
Value range:	0 to 65535
Unit:	0.1 m WS (≈ 0.98 kPa = 0.0098 bar)

This Read-Point returns the min possible pressure. It is the pressure that is set when the operation mode is set to “ Δp -v regulation” and the set value is below the corresponding percentage for min pressure.

Note: pumps that does not support “ Δp -v regulation” either sets the values to the same as the Δp -c min value or does not respond with data on this Read-Point. This Read-Point should not be used to see if the pump supports Δp -v regulation.

5.2.18 Max Flow Rate

Read-Point address: 24
Type: 32
Value range: 0 to 65535
Unit: 0.1 m³/h

This Read-Point returns the max possible flow rate in steps of 0.1 cubic meters per hour.

Note: pumps that does not support this Read-Point either sets the value to 9999 (decimal) or does not respond with data on this Read-Point.

5.2.19 Min Flow Rate

Read-Point address: 25
Type: 32
Value range: 0 to 65535
Unit: 0.1 m³/h

This Read-Point returns the min possible flow rate in steps of 0.1 cubic meters per hour.

Note: pumps that does not support this Read-Point either sets the value to 9999 (decimal) or does not respond with data on this Read-Point.

5.2.20 Supported Errors

Read-Point address: 26
Type: 32
Value range: 0 to 0xFFFF
Unit: See Table 5.9.

This Read-Point returns the supported errors that can be read in the Read-Point 37 (Error Message). It is a bit set value, and a “1” means that the specified error is supported and a “0” means that it is not supported. See Table 5.9.

5.2.21 Supported Service Messages

Read-Point address: 27
Type: 32
Value range: 0 to 0xFFFF
Unit: See Table 5.7.

This Read-Point returns the supported service messages that can be read in the Read-Point 35 (Service Message). It is a bit set value, and a “1” means that the specified error is supported and a “0” means that it is not supported. See Table 5.7.

5.2.22 Max Power Rating

Read-Point address: 28
Type: 3
Value range: 0 to 65535
Unit: 1 W

This Read-Point returns the maximum power rating under normal circumstances for the pump in Watts.

5.2.23 Service Message

Read-Point address: 35
Type: 3
Value range: 0 to 0xFFFF
Unit: See Table 5.7.

This Read-Point returns the actual service needed, see Table 5.7.

Bit number	Bit = 1	Bit = 0	Note
0	Service needed ¹	No service needed	
1	Exchange bearing ¹	No service needed	
2	Oil bearing ¹	No service needed	
3	Change sealing ¹	No service needed	

All other bits are unspecified and can be either '0' or '1'.

¹⁾ *In the case of a double pump, this applies to both master and slave.*

Table 5.7, Service Message bit set

5.2.24 Error Type

Read-Point address: 36
Type: 3
Value range: 0 to 0xFFFF
Unit: see Table 5.8.

This Read-Point returns the pump error. If one bit is active an error is present. A possible list of errors is located in the pump manual.

Bit number	Bit = 1	Bit = 0	Note
0	Module error	No error	
1	Motor error	No error	
2	Reserved	Reserved	
3	Pump error	No error	
4	Supply voltage error	No error	

All other bits are unspecified and can be either '0' or '1'.

Table 5.8, Error Type bit set

5.2.25 Error Message

Read-Point address: 37
Type: 3
Value range: 0 to 0xFFFF
Unit: See Table 5.9.

This Read-Point returns the error as specified in Table 5.9. No warnings are transmitted over the bus, only Errors (when the SSM relay becomes active in the Pump).

Bit number	Bit = 1	Bit = 0	Note
0	Undervoltage ¹	No error	E04
1	Overvoltage ¹	No error	E05
2	One phase missing ¹	No error	E06
3	Idle running ¹	No error	E11
4	System pressure too high ¹	No error	
5	System pressure too low ¹	No error	
8	Motor overheated ¹	No error	E20
9	Motor error ¹	No error	E16, E21, E23, E24, E25, E26
10	Pump blocked ¹	No error	E10, E12
11	Module overheated ¹	No error	
12	Module warning ¹	No error	E30, E31, E34, E52
13	Module error ¹	No error	E36, E37, E50
14	Sensor malfunction ¹	No error	E27, E38, E40, E41

All other bits are unspecified and can be either '0' or '1'.
¹⁾ *In the case of a double pump, this applies to both master and slave.*

Table 5.9, Error Message bit set

5.2.26 Pump Status

Read-Point address: 38
Type: 3
Value range: 0 to 0xFFFF
Unit: see Table 5.10.

This Read-Point returns the actual pump status.

Bit number	Bit = 1	Bit = 0	Note
0	Pump running	Pump not running	
1	Left rotation	Right rotation	
2	Difference >±10%	Difference <±10%	Actual and set point difference
3	Extern off active	Extern off not active	
4	Double pump	Single pump	
5	Manual override	Normal mode	Is set when "manual override is set by the IR-Monitor.
6	Q/H values are invalid	Normal mode	
7	Extern min active	Extern min not active	
13	Wink/Service mode	Normal mode	

All other bits are unspecified and can be either '0' or '1'.

Table 5.10, Pump Status bit set

5.2.27 State Diagnostics

Read-Point address: 39
Type: 3
Value range: 0 to 0xFFFF
Unit: See Table 5.11.

This Read-Point returns some information about the pump.

Bit number	Bit = 1	Bit = 0	Note
0	Pump or module error ¹	No error	Activated on all Errors.
1	Supply error ¹	No error	Activated on E04, E05 and E06.
3	Max regulation limit reached ¹	Normal operation	
4	Min regulation limit reached ¹	Normal operation	
6	Set value out of range ¹	Normal operation	
8	Manual override	Normal operation	Is set when "manual override is set by the IR-Monitor.
10	Pump running ¹	Pump stopped	

All other bits are unspecified and can be either '0' or '1'.

¹⁾ *In the case of a double pump, this applies to both master and slave.*

Table 5.11, State diagnostics bit set

5.3 Read-Point Parameters (special for a Double Pump)

These parameters are not supported by single pumps and are left unanswered. To see whether a pump is a double pump or not, bit number 4 in Read-Point 38 (Pump Status) should be read and evaluated.

Note: If the power to the slave is interrupted, the master automatically switches over to being a single pump.

Read-Point address	Description	Data Type	Unit
9	Operating Hours DP	33	10 h
65	Actual Differential Pressure (Slave)	32	0.1 m WS ¹
66	Flow Rate (Slave)	32	0.1 m ³ /h
67	Power Consumption (Slave)	3	1 kWh
68	Power Rating (Slave)	3	1 W
69	Operating Hours (Slave)	33	10 h
70	Mains Current (Slave)	32	0.1 A
71	Speed (Slave)	3	1 rpm
80	Pump Module (Slave)	1	See Table 5.5.
81	Pump Type (Slave)	1	See Table 5.6.
100	Error Type (Slave)	100	See Table 5.8.
102	Pump Status (Slave)	102	See Table 5.10.

¹⁾ *1 m WS ≈ 9.8 kPa = 0.098 bar*

Table 5.12, Double Pump specific Read-Point addresses

5.3.1 Operating Hours DP

Read-Point address: 9
Type: 32
Value range: 0 to 65534
Unit: 10 h

This Read-Point returns the operating hours of the double pump.

5.3.2 Actual Differential Pressure (Slave)

Read-Point address: 65
Type: 32
Value range: 0 to 65534
Unit: 0.1 m WS (≈ 0.98 kPa = 0.0098 bar)

This Read-Point returns the actual differential pressure of the slave in a double pump.

5.3.3 Flow Rate (Slave)

Read-Point address: 66
Type: 32
Value range: 0 to 65534
Unit: 0.1 m³/h

This Read-Point returns the actual flow rate of the slave in a double pump.

Note: A pump that does not support this Read-Point sets the value to 9999 (decimal).

5.3.4 Power Consumption (Slave)

Read-Point address: 67
Type: 3
Value range: 0 to 65534
Unit: 1 kWh

This Read-Point returns the total power consumption in kWh of the Slave in a double pump.

5.3.5 Power Rating (Slave)

Read-Point address: 68
Type: 3
Value range: 0 to 65534
Unit: 1 W

This Read-Point returns the current power rating of the Slave in a double pump.

5.3.6 Operating Hours (Slave)

Read-Point address: 69
Type: 33
Value range: 0 to 65534
Unit: 10 h

This Read-Point returns the operation hours of the Slave in a double pump.

5.3.7 Mains Current (Slave)

Read-Point address:	70
Type:	32
Value range:	0 to 65534
Unit:	0.1 A

This Read-Point returns the mains current of the Slave in a double pump.

5.3.8 Speed (Slave)

Read-Point address:	71
Type:	3
Value range:	0 to 65534
Unit:	1 rpm

This Read-Point returns the current speed of the Slave in a double pump.

5.3.9 Pump Module (Slave)

Read-Point address:	80
Type:	1
Value range:	0 to 255
Unit:	see Table 5.5.

This Read-Point returns the module type of the Slave in a double pump.

5.3.10 Pump Type (Slave)

Read-Point address:	81
Type:	1
Value range:	0 to 255
Unit:	see Table 5.6.

This Read-Point returns the pump type of the Slave in a double pump.

5.3.11 Error Type (Slave)

Read-Point address:	100
Type:	3
Value range:	0 to 0xFFFF
Unit:	see Table 5.8.

This Read-Point returns the error of the Slave in a double pump.

5.3.12 Pump Status (Slave)

Read-Point address:	102
Type:	3
Value range:	0 to 0xFFFF
Unit:	see Table 5.10.

This Read-Point returns the pump status of the Slave in a double pump.

6 Pump Support

This chapter contains the supported parameters by Pump.

6.1 Write-Point Parameters

These are the supported parameters for the following pump categories.

Write-Point address	Description	Stratos, TOP-E	MHIE, MVIE, MWISE	IP-E, IL-E
1	Set Value	yes	yes	yes
40	Pump Command	yes	see Table 6.2	see Table 6.2
42	Operation Mode	yes	see Table 6.3	see Table 6.3
44	Tmin for Δp -T	yes	no ¹⁾	no ¹⁾
45	Tmax for Δp -T	yes	no ¹⁾	no ¹⁾
46	pmin for Δp -T	yes	no ¹⁾	no ¹⁾
47	pmax for Δp -T	yes	no ¹⁾	no ¹⁾

¹⁾ Write-Point not supported by the pump, but the value can be written to the Modbus and read from the Modbus module.

Table 6.1, Write-Point pump support

6.1.1 Pump Command

Bit number	Description	Stratos, TOP-E	MHIE, MVIE, MWISE	IP-E, IL-E
0	Pump on/off	yes	yes	yes
1	Min Speed	yes	yes	yes
2	Max Speed	yes	yes	yes
3	Reserved	no	no	no

Table 6.2, Pump Command pump support

6.1.2 Operation Mode

If the pump does not support the write value, the mode Δp -c (p-c) regulation is automatically selected.

Value	Operation mode	Stratos, TOP-E	MHIE, MVIE, MWISE	IP-E, IL-E
0	Unknown	no	no	no
1	Fixed speed	yes	yes	yes
2	Reserved	no	no	no
3	Δp -c regulation	yes	yes (p-c)	yes
4	Δp -v regulation	yes	no	yes
5	Reserved	no	no	no
6	Δp -T regulation	yes	no	no

Table 6.3, Operation Mode pump support

6.2 Read-Point Parameters (Single Pump)

These are the supported parameters for the following pump categories.

Read-Point address	Description	Stratos, TOP-E	MHIE, MVIE, MVISE	IP-E, IL-E
1	Actual Differential Pressure	yes	yes (p-c)	yes
2	Flow Rate	yes	no, always 9999	yes
3	Power Consumption	yes	yes	yes
4	Power Rating	yes	yes	yes
5	Operation Hours	yes	yes	yes
6	Mains Current	yes	yes	yes
7	Speed	yes	yes	yes
8	Medium Temperature	yes	no	no
10	Current Operation Mode	see Table 6.3	see Table 6.3	see Table 6.3
16	Pump Module	see Table 6.5	see Table 6.5	see Table 6.5
17	Pump Type	yes	yes	yes
18	Max Speed	yes	yes	yes
19	Min Speed	yes	yes	yes
20	Max Pressure Δp -c	yes	yes	yes
21	Min Pressure Δp -c	yes	yes	yes
22	Max Pressure Δp -v	yes	Max Pressure p-c	yes
23	Min Pressure Δp -v	yes	Min Pressure p-c	yes
24	Max Flow Rate	yes	yes	yes
25	Min Flow Rate	yes	yes	yes
26	Supported Errors	see Table 6.8	see Table 6.8	see Table 6.8
27	Supported Service Messages	see Table 6.6	see Table 6.6	see Table 6.6
28	Max Power Rating	yes	yes	yes
35	Service Message	see Table 6.6	see Table 6.6	see Table 6.6
36	Error Type	see Table 6.7	see Table 6.7	see Table 6.7
37	Error Message	see Table 6.8	see Table 6.8	see Table 6.8
38	Pump Status	see Table 6.9	see Table 6.9	see Table 6.9
39	State Diagnostics	see Table 6.10	see Table 6.10	see Table 6.10

Table 6.4, Read-Point pump support

6.2.1 Pump Module

Bit number	Bit = 1	Stratos, TOP-E	MHIE, MVIE, MWISE	IP-E, IL-E
0	Pump is regulated with a frequency-converter	yes, always 1	yes, always 1	yes, always 1

Table 6.5, Pump Module Info support

6.2.2 Service Message

Bit number	Bit = 1	Stratos, TOP-E	MHIE, MVIE, MWISE	IP-E, IL-E
0	Service needed	yes	yes	yes
1	Exchange bearing	yes	no, always 0	no, always 0
2	Oil bearing	yes	no, always 0	no, always 0
3	Change sealing	yes	no, always 0	no, always 0

Table 6.6, Service Message bit set support

6.2.3 Error Type

Bit number	Bit = 1	Stratos, TOP-E	MHIE, MVIE, MWISE	IP-E, IL-E
0	Module error	yes	yes	yes
1	Motor error	yes	yes	yes
2	Reserved	yes	yes	yes
3	Pump error	yes	yes	yes
4	Supply voltage error	yes	yes	yes

Table 6.7, Error Type bit set support

6.2.4 Error Message

Bit number	Bit = 1	Stratos, TOP-E	MHIE, MVIE, MWISE	IP-E, IL-E
0	Undervoltage	yes	yes	yes
1	Overvoltage	yes	yes	yes
2	One phase missing	yes	yes	yes
3	Idle running	yes	yes	no, always 0
4	System pressure too high	yes	no, always 0	no, always 0
5	System pressure too low	yes	no, always 0	no, always 0
8	Motor overheated	yes	yes	yes
9	Motor error	yes	yes	yes
10	Pump blocked	yes	yes	yes
11	Module overheated	yes	yes	yes
12	Module warning	yes	yes	yes
13	Module error	yes	yes	yes
14	Sensor malfunction	yes	yes, (4-20mA)	no, always 0

Table 6.8, Error Message bit set support

6.2.5 Pump Status

Bit number	Bit = 1	Stratos, TOP-E	MHIE, MVIE, MWISE	IP-E, IL-E
0	Pump running	yes	yes	yes
1	Rotation direction	yes	yes	yes
2	Difference $\pm 10\%$	yes	yes	yes
3	Extern off	yes	yes	yes
4	Single/Double pump	yes	yes, always 0	yes
5	Manual override	yes	yes	yes
6	Q/H values invalid	yes	yes, always 1	yes
7	Extern min	yes	no, always 0	no, always 0
13	Wink/Service	yes	yes	yes

Table 6.9, Pump Status bit set support

6.2.6 State Diagnostics

Bit number	Bit = 1	Stratos, TOP-E	MHIE, MVIE, MVISE	IP-E, IL-E
0	Pump or module error	yes	yes	yes
1	Supply error	yes	yes	yes
3	Max regulation limit reached	yes	yes	yes
4	Min regulation limit reached	yes	yes	yes
6	Set value out of range	yes	yes	yes
8	Manual override	yes	yes	yes
10	Pump running	yes	yes	yes

Table 6.10, State diagnostics bit set support

6.3 Read-Point Parameters (special for a Double Pump)

These are the supported parameters for the following pump categories.

Read-Point address	Description	Stratos, TOP-E	MHIE, MVIE, MVISE	IP-E, IL-E
9	Operating Hours DP	yes	always 0	yes
65	Actual Differential Pressure (Slave)	yes	yes	yes
66	Flow Rate (Slave)	yes	yes	yes
67	Power Consumption (Slave)	yes	yes	yes
68	Power Rating (Slave)	yes	yes	yes
69	Operating Hours (Slave)	yes	yes	yes
70	Mains Current (Slave)	yes	yes	yes
71	Speed (Slave)	yes	yes	yes
80	Pump Module (Slave)	see Table 6.5	see Table 6.5	see Table 6.5
81	Pump Type (Slave)	yes	yes	yes
100	Error Type (Slave)	see Table 6.7	see Table 6.7	see Table 6.7
102	Pump Status (Slave)	see Table 6.9	see Table 6.9	see Table 6.9

Table 6.11, Double Pump specific Read-Point addresses support

7 Transaction Examples

7.1 Single Pump

7.1.1 Example 1: Simple Write

Sending the commands Pump On to the pump with address 1.

Request Description	Value	Response Description	Value
Device address	1	Device address	1
Function code	6	Function code	6
Register address High	0	Register address High	0
Register address Low	40	Register address Low	40
Register value High	0	Register value High	0
Register value Low	9	Register value Low	9
CRC Low	0xC9	CRC Low	0xC9
CRC High	0xC4	CRC High	0xC4

Table 7.1, a simple Write example

7.1.2 Example 2: Simple Read

Reading the Actual Differential Pressure from the pump with address 10. The pump answers, that it is running with a pressure of 4,5 m WS.

Request Description	Value	Response Description	Value
Device address	10	Device address	10
Function code	4	Function code	4
Starting Address High	0	Byte Count	2
Starting Address Low	1	Register Value 1 High	0
Quantity of RegistersHi	0	Register Value 1 Low	45
Quantity of RegistersLo	1	CRC Low	0xDD
CRC Low	0x61	CRC High	0x02
CRC High	0x71		

Table 7.2, a simple read example

7.1.3 A Write example with an error response

Trying to use read the Write-Point 47, but it is not supported and an error 2 is sent as response.

Request Description	Value	Response Description	Value
Device address	1	Device address	1
Function code	3	Function code	0x83
Register address High	0	Exception code	2
Register address Low	47	CRC Low	0xC0
Register value High	0	CRC High	0xF1
Register value Low	0		
CRC Low	0xF5		
CRC High	0xDF		

Table 7.3, a read write example with unanswered data

7.2 Double Pump

The difference between a single pump and a double pump is that one bit is set in Status register (Read-Point 38) and that more Read-Points are accessible.

7.2.1 Example 4: Simple Read

Reading Pump Status from the pump with address 8. The pump reports that it is off and that it is a double pump.

Request Description	Value	Response Description	Value
Device address	8	Device address	8
Function code	4	Function code	4
Starting Address High	0	Byte Count	2
Starting Address Low	38	Register Value 1 High	0
Quantity of RegistersHi	0	Register Value 1 Low	16
Quantity of RegistersLo	1	CRC Low	0x64
CRC Low	0xD0	CRC High	0xFD
CRC High	0x98		

Table 7.4, a read write example to a double pump

