

# **Definition of PLR on the RS485-bus**

**Version 1.04**



# Contents

<b>1</b>	<b>INTRODUCTION .....</b>	<b>4</b>
1.1	MOTIVATION .....	4
1.2	SCOPE OF THE DOCUMENT.....	4
1.3	VALUES .....	4
<b>2</b>	<b>ARCHITECTURAL OVERVIEW .....</b>	<b>5</b>
2.1	BUS TOPOLOGY .....	5
2.2	DATA FLOW.....	5
<b>3</b>	<b>HARDWARE REQUIREMENTS .....</b>	<b>6</b>
3.1.1	<i>RS485 Logical Signal Levels</i> .....	6
3.2	SUPPORTED WILO DEVICES .....	6
<b>4</b>	<b>PROTOCOL .....</b>	<b>7</b>
4.1	BYTE ORDERING AND FORMAT .....	7
4.1.1	<i>Supported Baud rates</i> .....	7
4.2	PACKET FIELDS .....	7
4.2.1	<i>Address field</i> .....	7
4.2.2	<i>Packet Type field</i> .....	7
4.2.3	<i>Number field</i> .....	7
4.2.4	<i>Data Type field</i> .....	8
4.2.5	<i>Write-Point address field</i> .....	8
4.2.6	<i>Write-Point data field</i> .....	8
4.2.7	<i>Read-Point address field</i> .....	8
4.2.8	<i>Read-Point data field</i> .....	8
4.2.9	<i>Checksum field</i> .....	8
4.3	PACKETS.....	9
4.3.1	<i>Request Packet</i> .....	9
4.3.2	<i>Response Packet</i> .....	9
4.4	PROTOCOL TIMING .....	10
4.4.1	<i>Byte Level</i> .....	10
4.4.2	<i>Packet Level</i> .....	10
4.5	PROTOCOL ERROR HANDLING .....	10
4.5.1	<i>Pump Communication Timeout</i> .....	11
4.5.2	<i>Gateway Communication Timeout</i> .....	11
<b>5</b>	<b>DEVICE PARAMETERS.....</b>	<b>12</b>
5.1	WRITE-POINT PARAMETERS .....	12
5.1.1	<i>Set value</i> .....	12
5.1.2	<i>Pump Command</i> .....	13
5.1.3	<i>Operation Mode</i> .....	13
5.1.4	<i>T<sub>min</sub> for Δp-T</i> .....	13
5.1.5	<i>T<sub>max</sub> for Δp-T</i> .....	14
5.1.6	<i>p<sub>min</sub> for Δp-T</i> .....	14
5.1.7	<i>p<sub>max</sub> for Δp-T</i> .....	14
5.2	READ-POINT PARAMETERS (SINGLE PUMP).....	15
5.2.1	<i>Actual Differential Pressure</i> .....	15
5.2.2	<i>Flow Rate</i> .....	16
5.2.3	<i>Power Consumption</i> .....	16
5.2.4	<i>Power Rating</i> .....	16
5.2.5	<i>Operation Hours</i> .....	16
5.2.6	<i>Mains Current</i> .....	16
5.2.7	<i>Speed</i> .....	16
5.2.8	<i>Medium Temperature</i> .....	16
5.2.9	<i>Current Operation Mode</i> .....	17
5.2.10	<i>Pump Module</i> .....	17
5.2.11	<i>Pump Type</i> .....	17
5.2.12	<i>Max Speed</i> .....	19

5.2.13	<i>Min Speed</i>	19
5.2.14	<i>Max Pressure <math>\Delta p-c</math></i>	19
5.2.15	<i>Min Pressure <math>\Delta p-c</math></i>	19
5.2.16	<i>Max Pressure <math>\Delta p-v</math></i>	19
5.2.17	<i>Min Pressure <math>\Delta p-v</math></i>	19
5.2.18	<i>Max Flow Rate</i>	20
5.2.19	<i>Min Flow Rate</i>	20
5.2.20	<i>Supported Errors</i>	20
5.2.21	<i>Supported Service Messages</i>	20
5.2.22	<i>Max Power Rating</i>	21
5.2.23	<i>Service Message</i>	21
5.2.24	<i>Error Type</i>	21
5.2.25	<i>Error Message</i>	21
5.2.26	<i>Pump Status</i>	22
5.2.27	<i>State Diagnostics</i>	23
5.3	<b>READ-POINT PARAMETERS (SPECIAL FOR A DOUBLE PUMP)</b>	23
5.3.1	<i>Operating Hours DP</i>	24
5.3.2	<i>Actual Differential Pressure (Slave)</i>	24
5.3.3	<i>Flow Rate (Slave)</i>	24
5.3.4	<i>Power Consumption (Slave)</i>	24
5.3.5	<i>Power Rating (Slave)</i>	24
5.3.6	<i>Operating Hours (Slave)</i>	24
5.3.7	<i>Mains Current (Slave)</i>	25
5.3.8	<i>Speed (Slave)</i>	25
5.3.9	<i>Pump Module (Slave)</i>	25
5.3.10	<i>Pump Type (Slave)</i>	25
5.3.11	<i>Error Type (Slave)</i>	25
5.3.12	<i>Pump Status (Slave)</i>	25
<b>6</b>	<b>PUMP SUPPORT</b>	<b>26</b>
6.1	<b>WRITE-POINT PARAMETERS</b>	26
6.1.1	<i>Pump Command</i>	26
6.1.2	<i>Operation Mode</i>	26
6.2	<b>READ-POINT PARAMETERS (SINGLE PUMP)</b>	27
6.2.1	<i>Pump Module</i>	28
6.2.2	<i>Service Message</i>	28
6.2.3	<i>Error Type</i>	28
6.2.4	<i>Error Message</i>	29
6.2.5	<i>Pump Status</i>	29
6.2.6	<i>State Diagnostics</i>	30
6.3	<b>READ-POINT PARAMETERS (SPECIAL FOR A DOUBLE PUMP)</b>	30
<b>7</b>	<b>TRANSACTION EXAMPLES</b>	<b>31</b>
7.1	<b>SINGLE PUMP</b>	31
7.1.1	<i>Example 1: Simple Write</i>	31
7.1.2	<i>Example 2: Simple Read</i>	31
7.1.3	<i>A Read/Write example with unanswered data</i>	32
7.2	<b>DOUBLE PUMP</b>	32
7.2.1	<i>Example 4: Simple Read</i>	32
<b>8</b>	<b>VERSION HISTORY</b>	<b>33</b>

# 1 Introduction

---

## 1.1 Motivation

In order to make configuration and operation easier, many building components support some way of remote controlling. This remote controlling does not only make it possible for the janitor to monitor devices and open gates or doors, letting the roller blinds down etc. But it also makes automatic changes, as turning down the temperature at 6 p.m. or perhaps even when the last person has left.

In short: The communication between devices are becoming more and more common, and more and more different devices are connected to the main computer in order to allow what could be seen as an intelligent building.

This document describes the protocol that will enable a remote control of pumps and thus make it possible to incorporate them in the main building management system.

## 1.2 Scope of the Document

This document describes the protocol and is targeted to developers that need to communicate with Wilo pumps.

In the second chapter, a brief device setup is shown and some fundamental knowledge is described.

In the third chapter the hardware requirements are briefly explained. This chapter is only included as assistance and is not to be thought of as a complete hardware specification.

The fourth chapter describes the protocol, how a packet is built, what order the bytes have, the meaning of the packets and the timing of packets and signals. It also explains the error handling in the protocol.

The fifth chapter describes all read and write parameters and their function.

The sixth chapter contains detailed communication examples to a pump.

## 1.3 Values

All values in this document are decimal unless prefixed with "0x" for a hexadecimal value.

## 2 Architectural Overview

### 2.1 Bus Topology

The main computer or BMS is called master since it effectively request information from the pumps. All Gateways (or in extension, the pumps) are slaves and they only passively responds to the requests from the master.

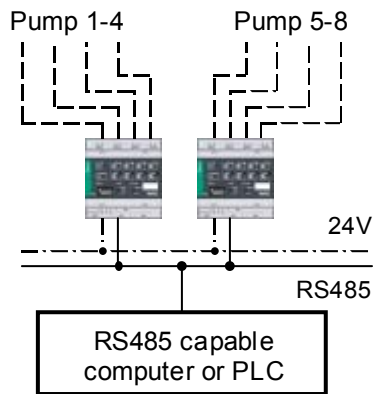
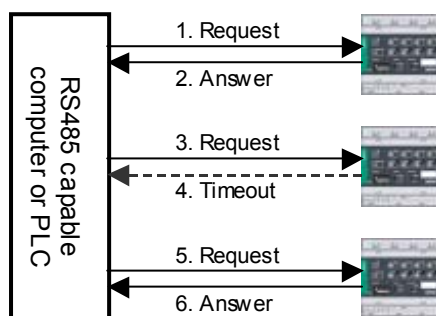

**Figure 2.1, Example of a simple configuration**

### 2.2 Data Flow

The DigiCon (the gateway to the pumps) continually read data from all its pumps and acts as a provider of this data on the RS485-bus. Similarly it collects the data from all writes and gives it to the corresponding connected Pump.

The communication on the RS485-bus is always master initiated. After a request an answer or timeout must take place, it is not allowed to send another request without waiting for an answer or timeout. Timing is described at the end of chapter 4.



**Figure 2.2, Example of the data flow**

The data is requested and sent by the master. It is then received and responded to by a slave. A slave cannot by itself initiate a transfer.

### 3 Hardware Requirements

The protocol described in this document is using the industry standard RS485 (for a specification see TIA/EIA-485). It is a two-wire bus protocol describing the physical and electrical levels of the wires. RS485 supports up to 32 connected transceivers (units) including the master, and allows a cable length up to 1000 meters.

*Note: Make sure that the ends of the RS485 bus are correctly terminated by a 120 Ohm resistor (See DigiCon Manual for further information).*

#### 3.1.1 RS485 Logical Signal Levels

When no unit is transmitting, A is negative and B is positive with respect to ground. In RS485 this level is specified as a logical '1'. Before any RS485 device sends its data on the bus, all units must know what format the data has, how many data bits, eventual a parity bit and how many stop bits. When data is to be sent it is always preceded by one start bit (a logical '0'). The data is transmitted with the LSB (bit 0) first and the data is followed by the eventual parity bit and then the stop bit (a logical '1').

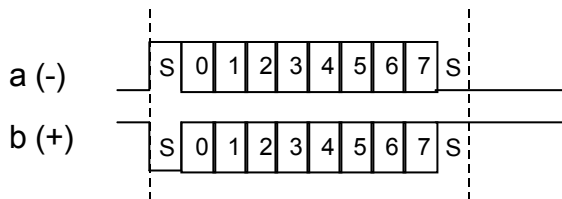

Figure 3.1, RS485 logical signal levels

#### 3.2 Supported Wilo devices

This specification applies to the following products.

Art.-No.	Description	Manufacturer
2062819	DigiCon	Wilo

Table 3.1, Products, compliant to PLR over RS485.

## 4 Protocol

### 4.1 Byte Ordering and format

In PLR, one byte is always transmitted with 1 start bit, 8 data bits and 1 stop bit. No parity is used in PLR. The data bits are sent LSB First and the bits are also numbered in this order, LSB = bit 0.

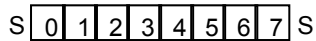

**Figure 4.1, one byte with start and stop bit**

No handshake protocol is implemented and a whole packet can be sent without a pause. Usually there are no gaps within a packet.

Byte ordering is Low byte before High byte. For example: The Write-Point 44 with data type 32 and value 3000 (0x0BB8) is sent as 0x2C, 0x20, 0xB8, 0x0B.

#### 4.1.1 Supported Baud rates

The DigiCon supports the following baud rates: 1200, 2400, 4800, 9600, 19200, 38400, 57600, 76800 and 115200.

### 4.2 Packet Fields

The packets consist of several different fields, and each field is defined as described below.

#### 4.2.1 Address field

The address field is always one byte and can contain the values 0 to 255. It contains the address of the slave that is addressed or the slave answering a request. The master always uses this field to direct the message to a specific slave. The slave always writes its own address in this field in order to tell the master from whom the answer came.

#### 4.2.2 Packet Type field

Every packet has a packet type and it describes the purpose of the packet. The packet type field has the size of one byte. It can have the values described in Table 4.1.

Packet Type Field	Description	Issuer
0	Response Packet (see Chapter 4.3.2)	Slave only
3	Request Packet (see Chapter 4.3.1)	Master only

**Table 4.1, Packet Types**

#### 4.2.3 Number field

The number field contains the number of following elements. The elements following the number field must be of the same size. This specific size is dependent on where and in what packet type the number field is located. See section 4.3.1 and section 4.3.2.

#### 4.2.4 Data Type field

When data is sent within a packet it is always accompanied with a data type. The data type has the size of one byte. It can have the values described in Table 4.2.

Data Type Field (Dec)	Description	Example Value	Example value Seen on bus
1	1 byte value in low-byte	0xF3	0xF3, 0x00
2	1 byte value in high-byte	0xF3	0x00, 0xF3
3	2 byte value with resolution 1	10	0x0A, 0x00
32	2 byte value with resolution 0.1	10.0	0x64, 0x00
33	2 byte value with resolution 10	10	0x01, 0x00

**Table 4.2, Data Types**

*Note: Data Types should not be used as the only source of formatting a parameter. For example: the Write-Point address 1 has the type 32, but the resolution is 0.5 (%).*

#### 4.2.5 Write-Point address field

The Write-Point address is always one byte and it tells the slave what Write-Point data follows so that it can be written at the correct position in the slave’s memory.

#### 4.2.6 Write-Point data field

Write-Point data is always sent as four bytes. The first byte is the Write-Point address (see Table 5.1), the second is the Write-Point Data Type (see Table 4.2) and the third and fourth contains the value that is to be written. A Write-Point parameter can only be written, it is not possible to read a Write-Point value from a pump.

#### 4.2.7 Read-Point address field

The Read-Point address is always one byte and it tells the slave what Read-Point data that is requested, or in a response packet, it precedes the actual values of the Read-Points that the master has requested.

#### 4.2.8 Read-Point data field

Read-Point data is always sent as four bytes. The first byte is the Read-Point address (see Table 5.4 and Table 5.12), the second is the Read-Point Data Type (see Table 4.2) and the third and fourth contains the value that has been read from the slave. The Read-Point parameters can only be read from a pump.

#### 4.2.9 Checksum field

The checksum has the size of exactly one byte, and it is the simple addition of all bytes before the checksum, represented as an 8 bit unsigned value (overflow is discarded). Examples can be found in chapter 6.

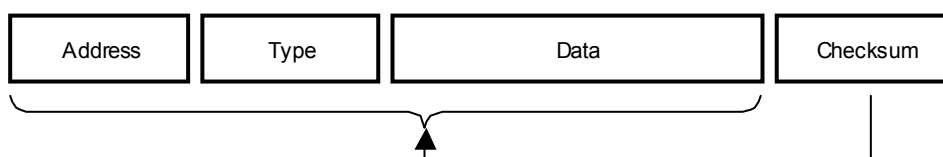

**Figure 4.2, Checksum**

### 4.3 Packets

#### 4.3.1 Request Packet

The Master always sends a request packet. In this packet both write and read requests can be sent together. It is allowed to set the number of writing or reading addresses to zero, if no data is to be written or read.

The first byte is the device address and the type of the packet (always 3 for a request packet). After these two bytes comes the number of write data points, followed by the data for the Write-Points. The Write-Point data is always sent as 4 bytes consisting of the Write-Point address, its type and the value to be written, the value is always 2 bytes long, even if only a one-byte value is to be transmitted. The number of Read-Point addresses, followed by the individual addresses that is to be read from the slave follows the Write-Point data. At the end of the packet the checksum is sent. It is the checksum for all bytes in the packet not including the checksum itself.

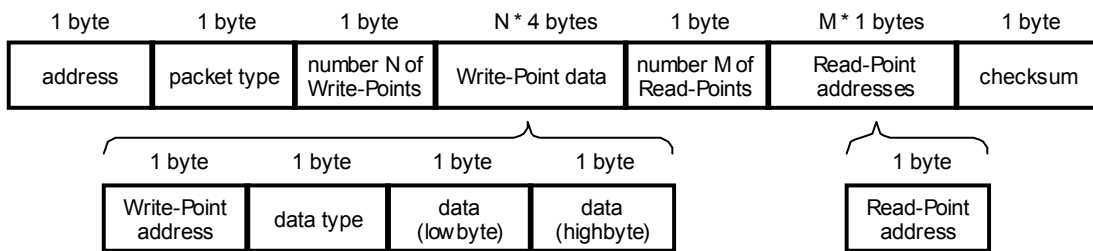

**Figure 4.3, Request Packet**

*Note: The maximum allowed size in bytes of a request packet is 72 bytes. Also the number (M) of Read-Points is limited to a maximum of 28 in one packet.*

#### 4.3.2 Response Packet

The Slave always responds with a response packet. In this packet only Read-Point data is sent. It is allowed to set the number of Read-Point data to zero, if no data can be read.

The first byte is the device address (of the slave) and the type of the packet (always 0 for a response packet). After these two bytes comes the number (L) of Read-Point data followed by the data for the Read-Points. The Read-Point data is always sent as 4 bytes consisting of the Read-Point address, its type and the value to be written, the value is always 2 bytes long, even if only a one-byte value is to be transmitted. At the end of the packet the checksum is sent. It is the checksum for all bytes in the packet excluding the checksum itself.

*Note: if no Read-Point is answered (empty packet) it could also mean that there is no pump connected or that the connected pump has a communication timeout (see section 4.5.1).*

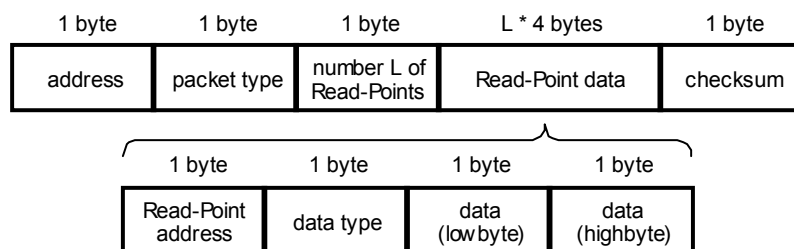

**Figure 4.4, Response Packet**

*Note: The response buffer in the master must be able to hold at least 120 bytes.*

#### 4.4 Protocol Timing

In order to allow for a stable communication, the PLR protocol has several specified timing constraints.

##### 4.4.1 Byte Level

A bit time is derived from the baud rate and as each packet always has 10 bits, the packet time is also easily calculated. Usually there are no delays in a transmitted packet. In a Packet the Between Byte time can be as small as 0 ms and is not allowed to exceed 25 ms.

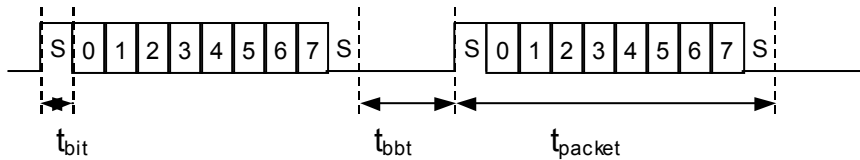

Figure 4.5, Byte level timing

Name	Description	Specified Time
$t_{bit}$	Bit time	1 / Baud rate (s)
$t_{packet}$	Packet time	10 / Baud rate (s)
$t_{bbt}$	Between byte time	0 to 25 ms <sup>1</sup>

<sup>1)</sup> Packets with a between byte time larger than 30 ms will not be correctly identified by the slave

Table 4.3, Byte level timing

##### 4.4.2 Packet Level

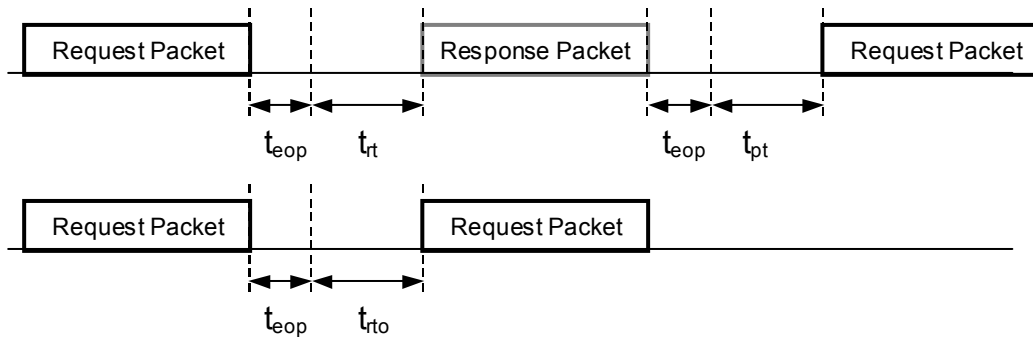

Figure 4.6, Packet level timing

Name	Description	Specified Time
$t_{eop}$	End of packet time	Max 30 ms
$t_{rt}$	Response time	Max 30 ms (for $\geq 4800$ baud) Max 50 ms (for 1200 and 2400 baud)
$t_{rto}$	Response time out	30 ms ( $\geq 4800$ baud) 50 ms (1200 and 2400 baud)
$t_{pt}$	Processing time	Max 30 ms

Table 4.4, Packet level timing

*Note: The PLR protocol is not intended for remote regulation. It can come to a delay up to a few seconds before the pump accepts the actual value.*

#### 4.5 Protocol Error Handling

PLR does not support errors at the protocol level. The only error that can be detected is the communication timeout.

#### **4.5.1 Pump Communication Timeout**

The DigiCon buffers the last value from the pump up to a minute after it has stopped transmitting. After this minute no data is returned on requests and the “empty packet” is sent. This empty packet consists of the address of the slave, the response packet type (always 0) and zero Read-Points (always 0). It thus ends with a checksum equal to the address of the slave (the packet is always sent as “X00X”, where the “X” stands for the actual address of the slave). In order to assure that an accidental reset of the DigiCon or the pump, does not trigger the communication timeout, it is suggested to wait one minute after receiving the first “empty packet”. If still no data is returned within this minute the master should issue a pump communication timeout for that specified pump.

#### **4.5.2 Gateway Communication Timeout**

If the Gateway is powered off it does not answer any requests for all its connected pumps, even if the pumps are still running. This must be detected by the master and the master should issue a Gateway communication timeout if no requests has been answered within a minute after the first unanswered request. A request does not count as unanswered when an “empty packet” is received.

## 5 Device Parameters

The Device Parameter space is split in two parts, the Write-Point parameters and the Read-Point parameters.

*Note: The Write-Point parameter with address 1 is thus not the same as the Read-Point parameter with address 1. They even have different Units.*

### 5.1 Write-Point Parameters

Write-Point address	Description	Data Type	Unit
1	Set Value	32	0.5%
40	Pump Command	1	See Table 5.2
42	Operation Mode	1	See Table 5.3
44	Tmin for $\Delta p$ -T	32	0.1 K
45	Tmax for $\Delta p$ -T	32	0.1 K
46	pmin for $\Delta p$ -T	32	0.1 m WS <sup>1</sup>
47	pmax for $\Delta p$ -T	32	0.1 m WS <sup>1</sup>

<sup>1)</sup> 1 m WS  $\approx$  9.8 kPa = 0.098 bar

Table 5.1, Write-Point addresses

#### 5.1.1 Set value

**Write-Point address:** 1  
**Type:** 32  
**Value range:** 0 to 200  
**Unit:** 0.5 %

The set value sets the wanted Speed or Pressure (depending on Operation mode, see section 5.1.3) in percent. Everything below the minimum value (speed or pressure,  $X_{min}$ ) of the pump is ignored, and the pump runs at minimum value (see Figure 5.1). It is not possible to turn the pump off with this parameter.

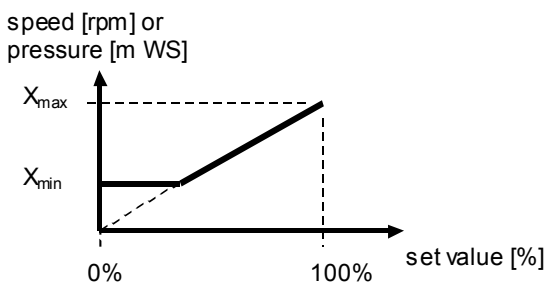

Figure 5.1, Set value curve

*Note: The Set Value should be sent as the last Write-Point in a packet.*

### 5.1.2 Pump Command

**Write-Point address:** 40  
**Type:** 1  
**Value range:** 0 to 0xFF  
**Unit:** see Table 5.2

This Write-Point controls the on, off, max speed and min speed modes of the pump.

*Note: "max speed" has priority over "min speed" and "on/off", and "min speed" has priority over "on/off".*

Bit number	Bit = 1	Bit = 0	Note
0	Pump on	Pump off	Bit number 1 and 2 has priority
1	Min Speed <sup>1</sup>	Normal operation	Bit number 2 has priority
2	Max Speed	Normal operation	
3	Reserved	Not allowed	Must always be '1'

*All other bits must be set to '0'*

<sup>1)</sup> *The actual speed in the Min Speed mode can differ slightly from the "min speed" Read-Point, it depends on what pump is connected and if it has a special value specified.*

**Table 5.2, Pump Command bit set**

### 5.1.3 Operation Mode

**Write-Point address:** 42  
**Type:** 1  
**Value range:** 0-6  
**Unit:** see Table 5.3

This Write-Point controls the operation mode of the pump. If a specified pump does not support the current selected mode it goes in mode 3 ( $\Delta p$ -c). The current operation mode can be read back by the Read-Point 11 (see section 5.2.9).

Value	Operation mode
0	Unknown
1	Fixed speed
2	Reserved
3	$\Delta p$ -c regulation
4	$\Delta p$ -v regulation
5	Reserved
6	$\Delta p$ -T regulation

*All other values are reserved and should not be used*

**Table 5.3, Operation Mode value**

### 5.1.4 $T_{min}$ for $\Delta p$ -T

**Write-Point address:** 44  
**Type:** 32  
**Value range:** 0 to ( $T_{max}$ )  
**Unit:** 0.1 K

This Write-Point sets a parameter for the temperature regulation. See Figure 5.2. This value must be lower than the value for  $T_{max}$ .

**5.1.5  $T_{max}$  for  $\Delta p$ -T**

**Write-Point address:** 45  
**Type:** 32  
**Value range:** ( $T_{min}$ ) to 65534  
**Unit:** 0.1 K

This Write-Point sets a parameter for the temperature regulation. See Figure 5.2. This value must be higher than the value for  $T_{min}$ .

**5.1.6  $p_{min}$  for  $\Delta p$ -T**

**Write-Point address:** 46  
**Type:** 32  
**Value range:** 0 to 65534  
**Unit:** 0.1 m WS ( $\approx 0.98$  kPa = 0.0098 bar)

This Write-Point sets a parameter for the temperature regulation. See Figure 5.2. This value can be lower or higher than the value for  $p_{max}$ .

**5.1.7  $p_{max}$  for  $\Delta p$ -T**

**Write-Point address:** 47  
**Type:** 32  
**Value range:** 0 to 65534  
**Unit:** 0.1 m WS ( $\approx 0.98$  kPa = 0.0098 bar)

This Write-Point sets a parameter for the temperature regulation. See Figure 5.2. This value can be lower or higher than the value for  $p_{min}$ .

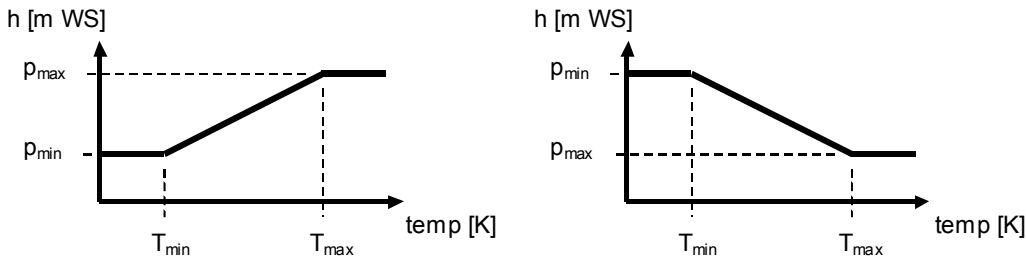

**Figure 5.2,  $\Delta p$ -T regulation with a high or low slope**

## 5.2 Read-Point Parameters (Single Pump)

Some pumps do not support some parameters. This means that some parameters can be left unanswered. Also some parameters give a special value when this parameter is not supported.

*Note: When a pump not supports a specific Read-Point parameter and leaves this parameter out of the response packet, the main control must be able to handle this and must not go into an unspecified state or crash.*

Read-Point address	Description	Data Type	Unit
1	Actual Differential Pressure	32	0.1 m WS <sup>1</sup>
2	Flow Rate	32	0.1 m <sup>3</sup> /h
3	Power Consumption	3	1 kWh
4	Power Rating	3	1 W
5	Operation Hours	33	10 h
6	Mains Current	32	0.1 A
7	Speed	3	1 rpm
8	Medium Temperature	32	0.1 K
10	Current Operation Mode	1	See Table 5.3.
16	Pump Module	1	See Table 5.5.
17	Pump Type	1	See Table 5.6.
18	Max Speed	3	1 rpm
19	Min Speed	3	1 rpm
20	Max Pressure $\Delta p$ -c	32	0.1 m WS <sup>1</sup>
21	Min Pressure $\Delta p$ -c	32	0.1 m WS <sup>1</sup>
22	Max Pressure $\Delta p$ -v	32	0.1 m WS <sup>1</sup>
23	Min Pressure $\Delta p$ -v	32	0.1 m WS <sup>1</sup>
24	Max Flow Rate	32	0.1 m <sup>3</sup> /h
25	Min Flow Rate	32	0.1 m <sup>3</sup> /h
26	Supported Errors	3	See Table 5.9.
27	Supported Service Messages	3	See Table 5.7.
28	Max Power Rating	3	1 W
35	Service Message	3	See Table 5.7.
36	Error Type	3	See Table 5.8.
37	Error Message	3	See Table 5.9.
38	Pump Status	3	See Table 5.10.
39	State Diagnostics	3	See Table 5.11.

<sup>1)</sup> 1 m WS  $\approx$  9.8 kPa = 0.098 bar

**Table 5.4, Read-Point addresses**

### 5.2.1 Actual Differential Pressure

**Read-Point address:** 1  
**Type:** 32  
**Value range:** 0 to 65535  
**Unit:** 0.1 m WS ( $\approx$  0.98 kPa = 0.0098 bar)

This Read-Point returns the actual differential pressure.

### 5.2.2 Flow Rate

**Read-Point address:** 2  
**Type:** 32  
**Value range:** 0 to 65535  
**Unit:** 0.1 m<sup>3</sup>/h

This Read-Point returns the current flow rate.

*Note: A pump that does not support this Read-Point sets the value to 9999 (decimal).*

### 5.2.3 Power Consumption

**Read-Point address:** 3  
**Type:** 3  
**Value range:** 0 to 65535  
**Unit:** 1 kWh

This Read-Point returns the total power consumption in kWh.

### 5.2.4 Power Rating

**Read-Point address:** 4  
**Type:** 3  
**Value range:** 0 to 65535  
**Unit:** 1 W

This Read-Point returns the current power rating in Watts.

### 5.2.5 Operation Hours

**Read-Point address:** 5  
**Type:** 33  
**Value range:** 0 to 65535  
**Unit:** 10 h

This Read-Point returns the operation hours in steps of 10 hours.

### 5.2.6 Mains Current

**Read-Point address:** 6  
**Type:** 32  
**Value range:** 0 to 65535  
**Unit:** 0.1 A

This Read-Point returns the mains current in steps of 0.1 Amperes

### 5.2.7 Speed

**Read-Point address:** 7  
**Type:** 3  
**Value range:** 0 to 65534  
**Unit:** 1 rpm

This Read-Point returns the current speed in rpm.

### 5.2.8 Medium Temperature

**Read-Point address:** 8  
**Type:** 32  
**Value range:** 0 to 65535  
**Unit:** 0.1 K

This Read-Point returns the Temperature. This value is only supported if the pump has a temperature sensor (TOP-E and STRATOS).

*Note: When this value is not supported, the pump does usually not respond to this Read-Point.*

### 5.2.9 Current Operation Mode

**Read-Point address:** 10  
**Type:** 1  
**Value range:** 0 to 8  
**Unit:** See Table 5.3.

This Read-Point returns the current operation mode.

### 5.2.10 Pump Module

**Read-Point address:** 16  
**Type:** 1  
**Value range:** 0 to 255  
**Unit:** see Table 5.5.

This Read-Point returns if the pump module is frequency converter regulated or not.

Bit number	Bit = 1	Bit = 0	Note
0	Pump is regulated with a frequency-converter	Pump is not regulated	

*All other bits are unspecified and can be either '0' or '1'.*

**Table 5.5, Pump Module Info**

### 5.2.11 Pump Type

**Read-Point address:** 17  
**Type:** 1  
**Value range:** 0 to 255  
**Unit:** see Table 5.6.

This Read-Point returns the pump type (see Table 5.6).



Value	Pump Type	Value	Pump Type
1	TOP-E 40 / 1 – 10 EP/DP	51	STRATOS 25/1-6 EP
2	TOP-E 50 / 1 – 7 EP/DP	52	STRATOS 30/1-6 EP
3	TOP-E 50 / 1 – 10 EP/DP	53	STRATOS 40/1-4 EP
4	TOP-E 65 / 1 – 10 EP/DP	54	STRATOS 25/1-8 EP
5	TOP-E 80 / 1 – 10 EP/DP	55	STRATOS 30/1-8 EP/DP
6	TOP-E 80 / 1 – 10n EP/DP	56	STRATOS 25/1-12 EP
7	TOP-E 25 / 1 – 7 EP		
8	TOP-E 30 / 1 – 10 EP	60	MHIE 205
9	TOP-E 40 / 1 – 4 EP	61	MHIE 403
10	TOP-E 50 / 1 – 6 EP/DP	62	MVIE 205
11	TOP-E 30 / 1 – 7 EP/DP	63	MVIE 403
12	TOP-E 40 / 1 – 10 IR EP/DP	64	MHIE 405
13	TOP-E 50 / 1 – 7 IR EP/DP	65	MHIE 803
14	TOP-E 50 / 1 – 10 IR EP/DP	66	MHIE 1602
15	TOP-E 65 / 1 – 10 IR EP/DP	67	MVIE 208
16	TOP-E 80 / 1 – 10 IR EP/DP	68	MVIE 406
17	TOP-E 40 / 1 – 7 IR EP/DP	69	MVIE 803
18	TOP-E 100 / 1 – 10 IR EP/DP	70	MVIE 1602
		71	MHIE 806
20	IP-E 32 / 5 – 28 EP/DP	72	MHIE 1603
21	IP-E 40 / 2 – 12 EP/DP	73	MVIE 214
23	IP-E 40 / 5 – 28 EP/DP	74	MVIE 410
24	IP-E 50 / 2 – 12 EP/DP	75	MVIE 806
26	IP-E 50 / 5 – 28 EP/DP	76	MVIE 1603
27	IP-E 65 / 2 – 15 EP/DP	77	MVISE 206
29	IP-E 65 / 4 – 20 EP/DP	78	MVISE 404
30	IP-E 80 / 2 – 15 EP/DP	79	MVISE 406
31	IP-E 80 / 4 – 20 EP/DP	80	MVISE 803
		81	MVISE 210
32	IL-E 50/10-36 EP(IL)/DP(DL)	82	MVISE 410
33	IL-E 65/6-24 EP(IL)/DP(DL)	83	MVISE 806
34	IL-E 80/5-22 EP(IL)/DP(DL)	84	SHCE20
35	IL-E 40/9-39 EP(IL)/DP(DL)		
36	IP-E 50/140-3/2 EP/DP	90	MVIE 414
37	IP-E 80/130-3/2 EP/DP	91	MVIE 808
38	IP-E 40/160-4/2 EP/DP	92	MVIE 1605
39	IP-E 65/140-4/2 EP/DP	93	MVIE 3202
		94	MVIE 811
40	STRATOS 30/1-12 EP	95	MVIE 1607
41	STRATOS 40/1-8 EP/DP	96	MVIE 3203
42	STRATOS 50/1-8 EP/DP	97	MVIE 5202
43	STRATOS 32/1-12 EP/DP		
44	STRATOS 40/1-12 EP/DP	101	IP-E 32/100-0.55/2
45	STRATOS 50/1-12 EP/DP	102	IP-E 32/110-0.75/2
46	STRATOS 50/1-9 EP/DP	103	IP-E 40/120-1.5/2
47	STRATOS 65/1-9 EP	104	IP-E 40/130-2.2/2
48	STRATOS 65/1-12 EP/DP	105	IP-E 50/130-2.2/2
49	STRATOS 80/1-12 EP/DP		
50	STRATOS 100/1-12 EP/DP		

Table 5.6, Pump Types

### 5.2.12 Max Speed

<b>Read-Point address:</b>	18
<b>Type:</b>	3
<b>Value range:</b>	0 to 65535
<b>Unit:</b>	1 rpm

This Read-Point returns the max possible speed of the pump. It is the speed that is set when operation mode is set to “fixed speed” and the set value is set to 100%.

### 5.2.13 Min Speed

<b>Read-Point address:</b>	19
<b>Type:</b>	3
<b>Value range:</b>	0 to 65535
<b>Unit:</b>	1 rpm

This Read-Point returns the min possible speed. It is the speed that is set when the operation mode is set to “fixed speed” and the set value is below the corresponding percentage for min speed.

### 5.2.14 Max Pressure $\Delta p$ -c

<b>Read-Point address:</b>	20
<b>Type:</b>	32
<b>Value range:</b>	0 to 65535
<b>Unit:</b>	0.1 m WS ( $\approx 0.98$ kPa = 0.0098 bar)

This Read-Point returns the max possible pressure. It is the pressure that is set when operation mode is set to “ $\Delta p$ -c regulation” and the set value is set to 100%.

### 5.2.15 Min Pressure $\Delta p$ -c

<b>Read-Point address:</b>	21
<b>Type:</b>	32
<b>Value range:</b>	0 to 65535
<b>Unit:</b>	0.1 m WS ( $\approx 0.98$ kPa = 0.0098 bar)

This Read-Point returns the min possible pressure. It is the pressure that is set when the operation mode is set to “ $\Delta p$ -c regulation” and the set value is below the corresponding percentage for min pressure.

### 5.2.16 Max Pressure $\Delta p$ -v

<b>Read-Point address:</b>	22
<b>Type:</b>	32
<b>Value range:</b>	0 to 65535
<b>Unit:</b>	0.1 m WS ( $\approx 0.98$ kPa = 0.0098 bar)

This Read-Point returns the max possible pressure. It is the pressure that is set when operation mode is set to “ $\Delta p$ -v regulation” and the set value is set to 100%.

*Note: pumps that does not support “ $\Delta p$ -v regulation” either sets the values to the same as the  $\Delta p$ -c max value or does not respond with data on this Read-Point. This Read-Point should not be used to see if the pump supports  $\Delta p$ -v regulation.*

### 5.2.17 Min Pressure $\Delta p$ -v

<b>Read-Point address:</b>	23
<b>Type:</b>	32
<b>Value range:</b>	0 to 65535
<b>Unit:</b>	0.1 m WS ( $\approx 0.98$ kPa = 0.0098 bar)

This Read-Point returns the min possible pressure. It is the pressure that is set when the operation mode is set to “ $\Delta p$ -v regulation” and the set value is below the corresponding percentage for min pressure.

*Note: pumps that does not support “ $\Delta p$ -v regulation” either sets the values to the same as the  $\Delta p$ -c min value or does not respond with data on this Read-Point. This Read-Point should not be used to see if the pump supports  $\Delta p$ -v regulation.*

### 5.2.18 Max Flow Rate

**Read-Point address:** 24  
**Type:** 32  
**Value range:** 0 to 65535  
**Unit:** 0.1 m<sup>3</sup>/h

This Read-Point returns the max possible flow rate in steps of 0.1 cubic meters per hour.

*Note: pumps that does not support this Read-Point either sets the value to 9999 (decimal) or does not respond with data on this Read-Point.*

### 5.2.19 Min Flow Rate

**Read-Point address:** 25  
**Type:** 32  
**Value range:** 0 to 65535  
**Unit:** 0.1 m<sup>3</sup>/h

This Read-Point returns the min possible flow rate in steps of 0.1 cubic meters per hour.

*Note: pumps that does not support this Read-Point either sets the value to 9999 (decimal) or does not respond with data on this Read-Point.*

### 5.2.20 Supported Errors

**Read-Point address:** 26  
**Type:** 32  
**Value range:** 0 to 0xFFFF  
**Unit:** See Table 5.9.

This Read-Point returns the supported errors that can be read in the Read-Point 37 (Error Message). It is a bit set value, and a “1” means that the specified error is supported and a “0” means that it is not supported. See Table 5.9.

### 5.2.21 Supported Service Messages

**Read-Point address:** 27  
**Type:** 32  
**Value range:** 0 to 0xFFFF  
**Unit:** See Table 5.7.

This Read-Point returns the supported service messages that can be read in the Read-Point 35 (Service Message). It is a bit set value, and a “1” means that the specified error is supported and a “0” means that it is not supported. See Table 5.7.

### 5.2.22 Max Power Rating

**Read-Point address:** 28  
**Type:** 3  
**Value range:** 0 to 65535  
**Unit:** 1 W

This Read-Point returns the maximum power rating under normal circumstances for the pump in Watts.

### 5.2.23 Service Message

**Read-Point address:** 35  
**Type:** 3  
**Value range:** 0 to 0xFFFF  
**Unit:** See Table 5.7.

This Read-Point returns the actual service needed, see Table 5.7.

Bit number	Bit = 1	Bit = 0	Note
0	Service needed <sup>1</sup>	No service needed	
1	Exchange bearing <sup>1</sup>	No service needed	
2	Oil bearing <sup>1</sup>	No service needed	
3	Change sealing <sup>1</sup>	No service needed	

*All other bits are unspecified and can be either '0' or '1'.*

*<sup>1)</sup> In the case of a double pump, this applies to both master and slave.*

**Table 5.7, Service Message bit set**

### 5.2.24 Error Type

**Read-Point address:** 36  
**Type:** 3  
**Value range:** 0 to 0xFFFF  
**Unit:** see Table 5.8.

This Read-Point returns the pump error. If one bit is active an error is present. A possible list of errors is located in the pump manual.

Bit number	Bit = 1	Bit = 0	Note
0	Module error	No error	
1	Motor error	No error	
2	Reserved	Reserved	
3	Pump error	No error	
4	Supply voltage error	No error	

*All other bits are unspecified and can be either '0' or '1'.*

**Table 5.8, Error Type bit set**

### 5.2.25 Error Message

**Read-Point address:** 37  
**Type:** 3  
**Value range:** 0 to 0xFFFF  
**Unit:** See Table 5.9.

This Read-Point returns the error as specified in Table 5.9. No warnings are transmitted over the bus, only Errors (when the SSM relay becomes active in the Pump).

Bit number	Bit = 1	Bit = 0	Note
0	Undervoltage <sup>1</sup>	No error	E04
1	Overvoltage <sup>1</sup>	No error	E05
2	One phase missing <sup>1</sup>	No error	E06
3	Idle running <sup>1</sup>	No error	E11
4	System pressure too high <sup>1</sup>	No error	
5	System pressure too low <sup>1</sup>	No error	
8	Motor overheated <sup>1</sup>	No error	E20
9	Motor error <sup>1</sup>	No error	E16, E21, E23, E24, E25, E26
10	Pump blocked <sup>1</sup>	No error	E10, E12
11	Module overheated <sup>1</sup>	No error	
12	Module warning <sup>1</sup>	No error	E30, E31, E34, E52
13	Module error <sup>1</sup>	No error	E36, E37, E50
14	Sensor malfunction <sup>1</sup>	No error	E27, E38, E40, E41

*All other bits are unspecified and can be either '0' or '1'.*  
<sup>1)</sup> *In the case of a double pump, this applies to both master and slave.*

**Table 5.9, Error Message bit set**

### 5.2.26 Pump Status

**Read-Point address:** 38  
**Type:** 3  
**Value range:** 0 to 0xFFFF  
**Unit:** see Table 5.10.

This Read-Point returns the actual pump status.

Bit number	Bit = 1	Bit = 0	Note
0	Pump running	Pump not running	
1	Left rotation	Right rotation	
2	Difference >±10%	Difference <±10%	Actual and set point difference
3	Extern off active	Extern off not active	
4	Double pump	Single pump	
5	Manual override	Normal mode	Is set when "manual override is set by the IR-Monitor.
6	Q/H values are invalid	Normal mode	
7	Extern min active	Extern min not active	
13	Wink/Service mode	Normal mode	

*All other bits are unspecified and can be either '0' or '1'.*

**Table 5.10, Pump Status bit set**

### 5.2.27 State Diagnostics

**Read-Point address:** 39  
**Type:** 3  
**Value range:** 0 to 0xFFFF  
**Unit:** See Table 5.11.

This Read-Point returns some information about the pump.

Bit number	Bit = 1	Bit = 0	Note
0	Pump or module error <sup>1</sup>	No error	Activated on all Errors.
1	Supply error <sup>1</sup>	No error	Activated on E04, E05 and E06.
3	Max regulation limit reached <sup>1</sup>	Normal operation	
4	Min regulation limit reached <sup>1</sup>	Normal operation	
6	Set value out of bounds <sup>1</sup>	Normal operation	
8	Manual override	Normal operation	Is set when “manual override is set by the IR-Monitor.
10	Pump running <sup>1</sup>	Pump stopped	

All other bits are unspecified and can be either ‘0’ or ‘1’.

<sup>1)</sup> In the case of a double pump, this applies to both master and slave.

**Table 5.11, State diagnostics bit set**

### 5.3 Read-Point Parameters (special for a Double Pump)

These parameters are not supported by single pumps and are left unanswered. To see whether a pump is a double pump or not, bit number 4 in Read-Point 38 (Pump Status) should be read and evaluated.

*Note: If the power to the slave is interrupted, the master automatically switches over to being a single pump.*

Read-Point address	Description	Data Type	Unit
9	Operating Hours DP	33	10 h
65	Actual Differential Pressure (Slave)	32	0.1 m WS <sup>1</sup>
66	Flow Rate (Slave)	32	0.1 m³/h
67	Power Consumption (Slave)	3	1 kWh
68	Power Rating (Slave)	3	1 W
69	Operating Hours (Slave)	33	10 h
70	Mains Current (Slave)	32	0.1 A
71	Speed (Slave)	3	1 rpm
80	Pump Module (Slave)	1	See Table 5.5.
81	Pump Type (Slave)	1	See Table 5.6.
100	Error Type (Slave)	100	See Table 5.8.
102	Pump Status (Slave)	102	See Table 5.10.

<sup>1)</sup> 1 m WS ≈ 9.8 kPa = 0.098 bar

**Table 5.12, Double Pump specific Read-Point addresses**

### 5.3.1 Operating Hours DP

**Read-Point address:** 9  
**Type:** 32  
**Value range:** 0 to 65534  
**Unit:** 10 h

This Read-Point returns the operating hours of the double pump.

### 5.3.2 Actual Differential Pressure (Slave)

**Read-Point address:** 65  
**Type:** 32  
**Value range:** 0 to 65534  
**Unit:** 0.1 m WS ( $\approx 0.98 \text{ kPa} = 0.0098 \text{ bar}$ )

This Read-Point returns the actual differential pressure of the slave in a double pump.

### 5.3.3 Flow Rate (Slave)

**Read-Point address:** 66  
**Type:** 32  
**Value range:** 0 to 65534  
**Unit:** 0.1 m<sup>3</sup>/h

This Read-Point returns the actual flow rate of the slave in a double pump.

*Note: A pump that does not support this Read-Point sets the value to 9999 (decimal).*

### 5.3.4 Power Consumption (Slave)

**Read-Point address:** 67  
**Type:** 3  
**Value range:** 0 to 65534  
**Unit:** 1 kWh

This Read-Point returns the total power consumption in kWh of the Slave in a double pump.

### 5.3.5 Power Rating (Slave)

**Read-Point address:** 68  
**Type:** 3  
**Value range:** 0 to 65534  
**Unit:** 1 W

This Read-Point returns the current power rating of the Slave in a double pump.

### 5.3.6 Operating Hours (Slave)

**Read-Point address:** 69  
**Type:** 33  
**Value range:** 0 to 65534  
**Unit:** 10 h

This Read-Point returns the operation hours of the Slave in a double pump.

### 5.3.7 Mains Current (Slave)

<b>Read-Point address:</b>	70
<b>Type:</b>	32
<b>Value range:</b>	0 to 65534
<b>Unit:</b>	0.1 A

This Read-Point returns the mains current of the Slave in a double pump.

### 5.3.8 Speed (Slave)

<b>Read-Point address:</b>	71
<b>Type:</b>	3
<b>Value range:</b>	0 to 65534
<b>Unit:</b>	1 rpm

This Read-Point returns the current speed of the Slave in a double pump.

### 5.3.9 Pump Module (Slave)

<b>Read-Point address:</b>	80
<b>Type:</b>	1
<b>Value range:</b>	0 to 255
<b>Unit:</b>	see Table 5.5.

This Read-Point returns the module type of the Slave in a double pump.

### 5.3.10 Pump Type (Slave)

<b>Read-Point address:</b>	81
<b>Type:</b>	1
<b>Value range:</b>	0 to 255
<b>Unit:</b>	see Table 5.6.

This Read-Point returns the pump type of the Slave in a double pump.

### 5.3.11 Error Type (Slave)

<b>Read-Point address:</b>	100
<b>Type:</b>	3
<b>Value range:</b>	0 to 0xFFFF
<b>Unit:</b>	see Table 5.8.

This Read-Point returns the error of the Slave in a double pump.

### 5.3.12 Pump Status (Slave)

<b>Read-Point address:</b>	102
<b>Type:</b>	3
<b>Value range:</b>	0 to 0xFFFF
<b>Unit:</b>	see Table 5.10.

This Read-Point returns the pump status of the Slave in a double pump.

## 6 Pump Support

This chapter contains the supported parameters by Pump.

### 6.1 Write-Point Parameters

These are the supported parameters for the following pump categories.

Write-Point address	Description	Stratos, TOP-E	MHIE, MVIE, MWISE	IP-E, IL-E
1	Set Value	yes	yes	yes
40	Pump Command	yes	see Table 6.2	see Table 6.2
42	Operation Mode	yes	see Table 6.3	see Table 6.3
44	Tmin for $\Delta p$ -T	yes	no <sup>1)</sup>	no <sup>1)</sup>
45	Tmax for $\Delta p$ -T	yes	no <sup>1)</sup>	no <sup>1)</sup>
46	pmin for $\Delta p$ -T	yes	no <sup>1)</sup>	no <sup>1)</sup>
47	pmax for $\Delta p$ -T	yes	no <sup>1)</sup>	no <sup>1)</sup>

<sup>1)</sup> Write-Point not supported by the pump, but the value can be written to the Modbus and read from the Modbus module.

Table 6.1, Write-Point pump support

#### 6.1.1 Pump Command

Bit number	Description	Stratos, TOP-E	MHIE, MVIE, MWISE	IP-E, IL-E
0	Pump on/off	yes	yes	yes
1	Min Speed	yes	yes	yes
2	Max Speed	yes	yes	yes
3	Reserved	no	no	no

Table 6.2, Pump Command pump support

#### 6.1.2 Operation Mode

If the pump does not support the write value, the mode  $\Delta p$ -c (p-c) regulation is automatically selected.

Value	Operation mode	Stratos, TOP-E	MHIE, MVIE, MWISE	IP-E, IL-E
0	Unknown	no	no	no
1	Fixed speed	yes	yes	yes
2	Reserved	no	no	no
3	$\Delta p$ -c regulation	yes	yes (p-c)	yes
4	$\Delta p$ -v regulation	yes	no	yes
5	Reserved	no	no	no
6	$\Delta p$ -T regulation	yes	no	no

Table 6.3, Operation Mode pump support

## 6.2 Read-Point Parameters (Single Pump)

These are the supported parameters for the following pump categories.

Read-Point address	Description	Stratos, TOP-E	MHIE, MVIE, MVISE	IP-E, IL-E
1	Actual Differential Pressure	yes	yes (p-c)	yes
2	Flow Rate	yes	no, always 9999	yes
3	Power Consumption	yes	yes	yes
4	Power Rating	yes	yes	yes
5	Operation Hours	yes	yes	yes
6	Mains Current	yes	yes	yes
7	Speed	yes	yes	yes
8	Medium Temperature	yes	no	no
10	Current Operation Mode	see Table 6.3	see Table 6.3	see Table 6.3
16	Pump Module	see Table 6.5	see Table 6.5	see Table 6.5
17	Pump Type	yes	yes	yes
18	Max Speed	yes	yes	yes
19	Min Speed	yes	yes	yes
20	Max Pressure $\Delta p-c$	yes	yes	yes
21	Min Pressure $\Delta p-c$	yes	yes	yes
22	Max Pressure $\Delta p-v$	yes	Max Pressure p-c	yes
23	Min Pressure $\Delta p-v$	yes	Min Pressure p-c	yes
24	Max Flow Rate	yes	yes	yes
25	Min Flow Rate	yes	yes	yes
26	Supported Errors	see Table 6.8	see Table 6.8	see Table 6.8
27	Supported Service Messages	see Table 6.6	see Table 6.6	see Table 6.6
28	Max Power Rating	yes	yes	yes
35	Service Message	see Table 6.6	see Table 6.6	see Table 6.6
36	Error Type	see Table 6.7	see Table 6.7	see Table 6.7
37	Error Message	see Table 6.8	see Table 6.8	see Table 6.8
38	Pump Status	see Table 6.9	see Table 6.9	see Table 6.9
39	State Diagnostics	see Table 6.10	see Table 6.10	see Table 6.10

**Table 6.4, Read-Point pump support**

### 6.2.1 Pump Module

Bit number	Bit = 1	Stratos, TOP-E	MHIE, MVIE, MWISE	IP-E, IL-E
0	Pump is regulated with a frequency-converter	yes, always 1	yes, always 1	yes, always 1

Table 6.5, Pump Module Info support

### 6.2.2 Service Message

Bit number	Bit = 1	Stratos, TOP-E	MHIE, MVIE, MWISE	IP-E, IL-E
0	Service needed	yes	yes	yes
1	Exchange bearing	yes	no, always 0	no, always 0
2	Oil bearing	yes	no, always 0	no, always 0
3	Change sealing	yes	no, always 0	no, always 0

Table 6.6, Service Message bit set support

### 6.2.3 Error Type

Bit number	Bit = 1	Stratos, TOP-E	MHIE, MVIE, MWISE	IP-E, IL-E
0	Module error	yes	yes	yes
1	Motor error	yes	yes	yes
2	Reserved	yes	yes	yes
3	Pump error	yes	yes	yes
4	Supply voltage error	yes	yes	yes

Table 6.7, Error Type bit set support

### 6.2.4 Error Message

Bit number	Bit = 1	Stratos, TOP-E	MHIE, MVIE, MWISE	IP-E, IL-E
0	Undervoltage	yes	yes	yes
1	Overvoltage	yes	yes	yes
2	One phase missing	yes	yes	yes
3	Idle running	yes	yes	no, always 0
4	System pressure too high	yes	no, always 0	no, always 0
5	System pressure too low	yes	no, always 0	no, always 0
8	Motor overheated	yes	yes	yes
9	Motor error	yes	yes	yes
10	Pump blocked	yes	yes	yes
11	Module overheated	yes	yes	yes
12	Module warning	yes	yes	yes
13	Module error	yes	yes	yes
14	Sensor malfunction	yes	yes, (4-20mA)	no, always 0

Table 6.8, Error Message bit set support

### 6.2.5 Pump Status

Bit number	Bit = 1	Stratos, TOP-E	MHIE, MVIE, MWISE	IP-E, IL-E
0	Pump running	yes	yes	yes
1	Rotation direction	yes	yes	yes
2	Difference <math>\pm 10\%</math>	yes	yes	yes
3	Extern off	yes	yes	yes
4	Single/Double pump	yes	yes, always 0	yes
5	Manual override	yes	yes	yes
6	Q/H values invalid	yes	yes, always 1	yes
7	Extern min	yes	no, always 0	no, always 0
13	Wink/Service	yes	yes	yes

Table 6.9, Pump Status bit set support

### 6.2.6 State Diagnostics

Bit number	Bit = 1	Stratos, TOP-E	MHIE, MVIE, MVISE	IP-E, IL-E
0	Pump or module error	yes	yes	yes
1	Supply error	yes	yes	yes
3	Max regulation limit reached	yes	yes	yes
4	Min regulation limit reached	yes	yes	yes
6	Set value out of range	yes	yes	yes
8	Manual override	yes	yes	yes
10	Pump running	yes	yes	yes

**Table 6.10, State diagnostics bit set support**

### 6.3 Read-Point Parameters (special for a Double Pump)

These are the supported parameters for the following pump categories.

Read-Point address	Description	Stratos, TOP-E	MHIE, MVIE, MVISE	IP-E, IL-E
9	Operating Hours DP	yes	always 0	yes
65	Actual Differential Pressure (Slave)	yes	yes	yes
66	Flow Rate (Slave)	yes	yes	yes
67	Power Consumption (Slave)	yes	yes	yes
68	Power Rating (Slave)	yes	yes	yes
69	Operating Hours (Slave)	yes	yes	yes
70	Mains Current (Slave)	yes	yes	yes
71	Speed (Slave)	yes	yes	yes
80	Pump Module (Slave)	see Table 6.5	see Table 6.5	see Table 6.5
81	Pump Type (Slave)	yes	yes	yes
100	Error Type (Slave)	see Table 6.7	see Table 6.7	see Table 6.7
102	Pump Status (Slave)	see Table 6.9	see Table 6.9	see Table 6.9

**Table 6.11, Double Pump specific Read-Point addresses support**

## 7 Transaction Examples

### 7.1 Single Pump

#### 7.1.1 Example 1: Simple Write

Sending the commands Pump On, Operation Mode  $\Delta p$ -c and a set value of 40% to the pump with address 1.

Request Description	Value	Response Description	Value
Address	1	Address	1
Packet type	3	Packet type	0
Number of Write-Points	3	Number of Read-Points	0
Write-Point Pump command	40	Checksum	1
Type	1		
Value (Low Byte)	9		
Value (High Byte)	0		
Write-Point Operation Mode	42		
Type	1		
Value (Low Byte)	3		
Value (High Byte)	0		
Write-Point	1		
Type	32		
Value, Low	80		
Value, High	0		
Number of Read-Points	0		
Checksum	216		

Table 7.1, a simple Write example

#### 7.1.2 Example 2: Simple Read

Reading the Actual Differential Pressure and the Power Rating from the pump with address 10. The pump answers that it is running with a pressure of 4,5 m WS and has a power rating of 550 W.

Request Description	Value	Response Description	Value
Address	10	Address	10
Packet type	3	Packet type	0
Number of Write-Points	0	Number of Read-Points	2
Number of Read-Points	2	Read-Point Act. Diff. Pressure	1
Read-Point Act. Diff. Pressure	1	Type	32
Read-Point Power Rating	4	Value (Low Byte)	45
Checksum	20	Value (High Byte)	0
		Read-Point Power Rating	4
		Type	3
		Value (Low Byte)	38
		Value (High Byte)	2
		Checksum	137

Table 7.2, a simple read example



**7.1.3 A Read/Write example with unanswered data**

Sending a set value of 50% and reading the Flow Rate and Medium Temperature. The pump does not support Temperature and does not answer this Read-Point. And the pump is in an operation mode that does not support Flow Rate so it returns the value 9999 (999.9 m³/h).

Request Description	Value	Response Description	Value
Address	10	Address	10
Packet type	3	Packet type	0
Number of Write-Points	1	Number of Read-Points	1
Write-Point	1	Read-Point Flow Rate	2
Type	32	Type	32
Value, Low	100	Value (Low Byte)	15
Value, High	0	Value (High Byte)	39
Number of Read-Points	2	Checksum	99
Read-Point Flow Rate	2		
Read-Point Medium Temperature	8		
Checksum	159		

**Table 7.3, a read write example with unanswered data**

**7.2 Double Pump**

The difference between a single pump and a double pump is that one bit is set in Status register (Read-Point 38) and that more Read-Points are accessible.

**7.2.1 Example 4: Simple Read**

Reading Pump Status and Operating Hours DP from the pump with address 0. The pump reports that it is off, that it is a double pump and that it has been running for 14580 hours.

Request Description	Value	Response Description	Value
Address	0	Address	0
Packet type	3	Packet type	0
Number of Write-Points	0	Number of Read-Points	2
Number of Read-Points	2	Read-Point Pump Status	38
Read-Point Pump Status	38	Type	3
Read-Point Operating Hours DP	9	Value (Low Byte)	16
Checksum	52	Value (High Byte)	0
		Read-Point Operating Hours DP	9
		Type	33
		Value (Low Byte)	178
		Value (High Byte)	5
		Checksum	28

**Table 7.4, a read write example to a double pump**





*The data in this document are subject to change without prior notice. Wilo cannot be held responsible for any problems caused directly or indirectly by using information in this document.*